

1.4 QGS Series Standard Cylinder

The cylinder diameter of this series $\phi 32 \sim \phi 320$, in accordance with ISO15552 standard, can be derived from various cylinders such as single acting, adjustable stroke, double output shaft, multi position, series connection, with directional valve, etc.

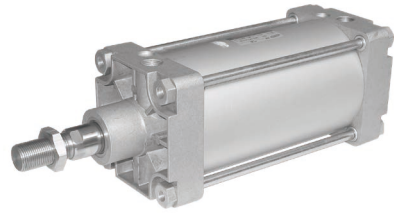

Summary

The cylinder diameter of this series $\phi 32 \sim \phi 320$, in accordance with ISO15552 standard, can be derived from various cylinders such as single acting, adjustable stroke, double output shaft, multi position, series connection, with directional valve, etc.

Models selection

QGS	-32	×50	-PPV	A	-2F		
Double-acting	①	②	③	④	⑤		
①	-Diameter: 32 40 50 63 80 100 125 160 200 250 320						
②	× Stroke: see stroke datasheet (Note: Multi-bit cylinder stroke representation method S1 × S2)						
③	-Buffer: P=Elastic buffering ring sat both ends;PPV=Pneumatic buffering, adjustable at both ends;						
④	Position sensing: A=Mounting magnetic ring;None=Without magnetic ring						
⑤	-Derivative types						
	The type of piston rod		Other types	Terminal position lock	Temperature range		
	With one side	L	The stroke can be adjust	E1	Both sides	Standard	
	2	Double-piston rod	P	Multi-position	E2	With advanced piston rod	T
F	Female thread	J	Series	E3	With retracted piston rod	R	Heat-resistant seals max.120 °C

Product features

- Anti corrosion: The cylinder barrel is made of high-quality aluminum alloy pipes, which have undergone hard anodizing treatment;
- Wear resistance: The piston rod is Pre-rolled and hardened, plated with hard chromium and finely ground, and has good rust prevention, wear resistance, and other characteristics;
- Free of oil supply: use oil-containing alloy and special bearing liner;
- Diversified brackets: Multiple fixed and non fixed brackets for customers to choose from.

Diagram



Technical parameters

General technical date											
Piston Diameter ϕ	32	40	50	63	80	100	125	160	200	250	320
Meet A Criterion	ISO 15552										
Mode of operation	Double-acting										
Pneumatic connection	G1/8	G1/4	G1/4	G3/8	G3/8	G1/2	G1/2	G3/4	G3/4	G1	G1
Piston rod thread	M10x1.25	M12x1.25	M16x1.5	M16x1.5	M20x1.5	M20x1.5	M27x2	M36x2	M36x2	M42x2	M48x2
Stork Error	0 ~ 250 $^{+1.0}_0$, 251~1000 $^{+1.5}_0$, 1001~2000 $^{+2.0}_0$										
Design	Piston/Piston rod/Profile barrel										
Cushioning	Pneumatic cushioning, adjustable at both ends										
Position sensing	Via the magnetic switch										
Type of mounting	Via female thread/accessories										
Mounting position	Any										
Operating and environmental conditions											
Operating medium	Compressed air (filtered by filter screen above 40 μ m)										
Operating PressureMPa	0.06 ... 1.2		0.04 ... 1.2				0.02 ... 1				
Environmental and fluid temperature	-20 ~ 80° C										
Corrosion resistance grade	2										

-Technical parameters

Forces [N] and impact energy [J]											
Piston Diameter ϕ	32	40	50	63	80	100	125	160	200	250	320
Theoretical force at 6bar, advancing	483	754	1178	1870	3016	4712	7363	12055	18840	29437	48230
Theoretical force at 6bar, retracting	415	633	990	1682	2721	4418	6881	11304	18086	28260	46361
Max. impact energy in the end positions	0.4	0.7	1.0	1.3	1.8	2.5	3.3	3.3	4	4.2	6
Note:	Permissible impact velocity: $v = \sqrt{\frac{2 \times E}{m_1 + m_2}}$ Maximum permissible mass: $m_2 = \frac{2 \times E}{v^2} - m_1$										
V Permissible impact velocity	This parameter represents the maximum value that can be reached.										
E Max. impact energy	Maximum allowable impact energy must be observed.										
m ₁ Moving mass (drive)											
m ₂ Moving payload											

Standard stroke datasheet (mm)

Diameter ϕ	Standard Stroke																Maximum stroke	Buffer stroke						
	25	50	80	100	125	160	200	250	320	400	500	600	700	800	900	1000			1100	1200	1500	1800	2000	
32																							320	21
40										↓	400	500											500	22
50											↓	600											600	26
63											↓	600											600	29
80											↓	700	800	900	1000								1000	31
100											↓	700	800	900	1000								1000	36
125															↓	1100	1200						1200	40
160															↓	1500							1500	50
200															↓	1500							1500	50
250																↓	1800	1800					1800	50
320																↓	2000	2000					2000	50

Note: Please contact us for any other special trips.

Structure Diagram

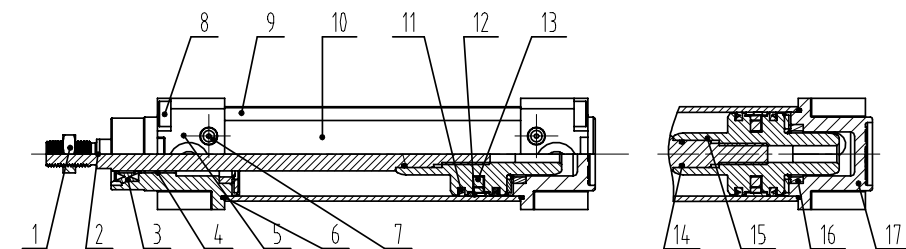

Standard cylinder								
[1]	Nut	Galvanized steel	[7]	Buffer regulating valve	Die-cast Aluminum	[13]	O Ring	NBR
[2]	Piston Rod	Improved Carbon Structural Steel	[8]	Blind nut	Carbon Structural Steel	[14]	O Ring	NBR
[3]	Axial Seal Ring	Polyurethane	[9]	Connecting Pod	Improved Carbon Structural Steel	[15]	Buffer Piston	Die-cast Aluminum
[4]	Guide sleeve	Engineering Plastics	[10]	Cylinder Body	Anodized refined aluminum alloy	[16]	Y Ring	NBR
[5]	Front cylinder head	Die-cast Aluminum	[11]	Y-type hole with ring	NBR	[17]	Rear cylinder cover	Die-cast Aluminum
[6]	O Ring	NBR	[12]	Wear-resistant support ring	POM			

Dimensions

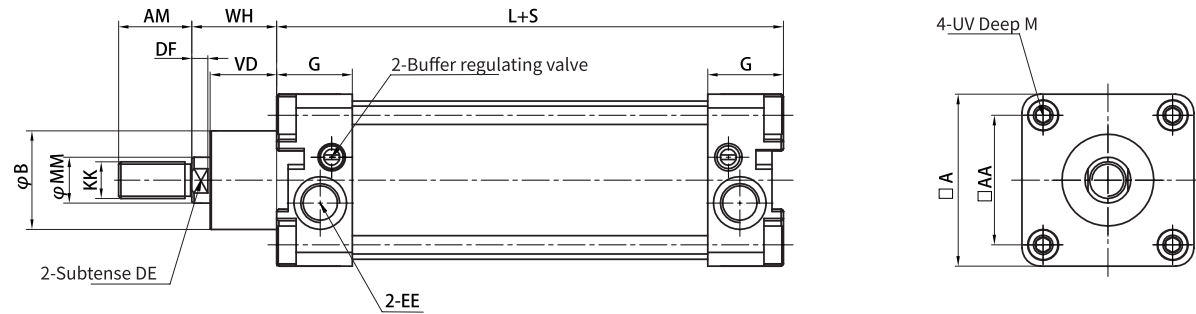

Diameter ϕ [mm]	A	AA	AM	B	DE	DF	EE	G	KK	L	M	MM	UV	VD	WH
32	47	32.5	22	30	10	5	G1/8	27.5	M10×1.25	94	10	12	M6	20	26
40	53	38	24	35	14	7	G1/4	32	M12×1.25	105	10	16	M6	22	30
50	65	46.5	32	40	17	8	G1/4	31	M16×1.5	106	10	20	M8	27	37
63	75	56.5	32	45	17	8	G3/8	33	M16×1.5	121	11	20	M8	29	37
80	95	72	40	45	22	12	G3/8	33	M20×1.5	128	13	25	M10	33	46
100	115	89	40	55	22	13	G1/2	37	M20×1.5	138	13	25	M10	36	51
125	140	110	54	60	27	16	G1/2	46	M27×2	160	15	32	M12	45	65
160	180	140	72	65	36	18	G3/4	50	M36×2	180	20	40	M16	55	80
200	220	175	72	75	36	18	G3/4	50	M36×2	180	20	40	M16	65	95
250	280	220	84	90	42	20	G1	50	M42×2	200	-	50	M20	75	105
320	350	270	96	110	55	20	G1	55	M48×2	220	-	63	M24	85	120

F - Female thread

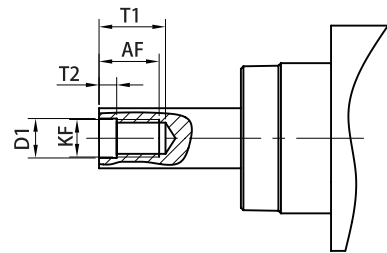

ϕ [mm]	AFmin.	D1	KF	T1max.	T2
32	12	6.4	M6	16	2.6
40	12	8.4	M8	16	3.3
50	16	10.5	M10	21	4.7
63	16	10.5	M10	21	4.7
80	20	13	M12	26.5	6.1
100	20	13	M12	26.5	6.1
125	32	17	M16	40	8

Installation method

LB Axial foundation Type

Material: Galvanized steel

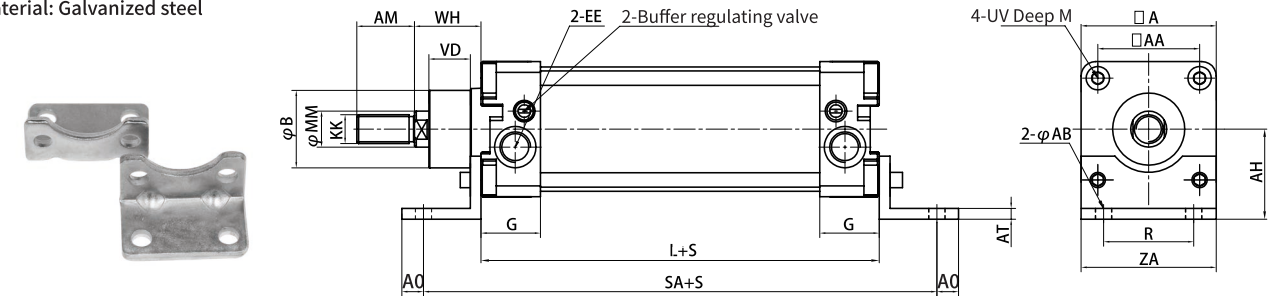

Diameter ϕ [mm]	A	AA	AB	AH	AM	A0	AT	B	EE	G	KK	L	MM	R	SA	UV	VD	WH	ZA
32	47	32.5	7	32	22	8	4	30	G1/8	27.5	M10X1.25	94	12	32	142	M6	20	26	47
40	53	38	9	36	24	10	4	35	G1/4	32	M12X1.25	105	16	36	161	M6	22	30	53
50	65	46.5	9	45	32	10	5	40	G1/4	31	M16X1.5	106	20	45	170	M8	27	37	62
63	75	56.5	9	50	32	12	5	45	G3/8	33	M16X1.5	121	20	50	185	M8	29	37	75
80	95	72	12	63	40	17	6	45	G3/8	33	M20X1.5	128	25	63	210	M10	33	46	94
100	115	89	14	71	40	20	6	55	G1/2	37	M20X1.5	138	25	75	220	M10	36	51	112
125	140	110	16	90	54	20	8	60	G1/2	46	M27X2	160	32	90	250	M12	45	65	140
160	180	140	18	115	72	20	10	65	G3/4	50	M36X2	180	40	115	300	M16	55	80	180
200	220	175	22	135	72	30	12	75	G3/4	50	M36X2	180	40	135	320	M16	55	95	220
250	280	220	26	165	84	35	20	90	G1	50	M42X2	200	50	165	350	M20	75	105	280
320	350	270	33	200	96	40	23	105	G1	55	M48X2	220	63	200	390	M24	85	120	350

FA Front Flange Type

Material: Galvanized steel

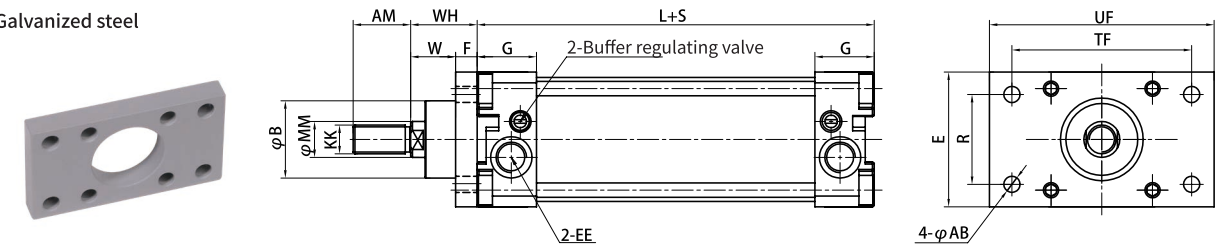

Diameter ϕ [mm]	AB	AM	B	E	EE	F	G	KK	L	MM	R	TF	UF	W	WH
32	7	22	30	47	G1/8	10	27.5	M10X1.25	94	12	32	64	80	16	26
40	9	24	35	53	G1/4	10	32	M12X1.25	105	16	36	72	90	20	30
50	9	32	40	65	G1/4	12	31	M16X1.5	106	20	45	90	110	25	37
63	9	32	45	75	G3/8	12	33	M16X1.5	121	20	50	100	125	25	37
80	12	40	45	95	G3/8	16	33	M20X1.5	128	25	63	126	154	30	46
100	14	40	55	115	G1/2	16	37	M20X1.5	138	25	75	150	185	35	51
125	16	54	60	140	G1/2	20	46	M27X2	160	32	90	180	220	45	65
160	18	72	65	180	G3/4	20	50	M36X2	180	40	115	230	280	60	80
200	22	72	75	220	G3/4	25	50	M36X2	180	40	135	270	320	70	95
250	26	84	90	280	G1	25	50	M42X2	200	50	165	330	390	80	105
320	28	96	110	350	G1	30	55	M48X2	220	63	200	400	470	90	120

-Installation method

FB Rear Flange Type

Material: Galvanized steel

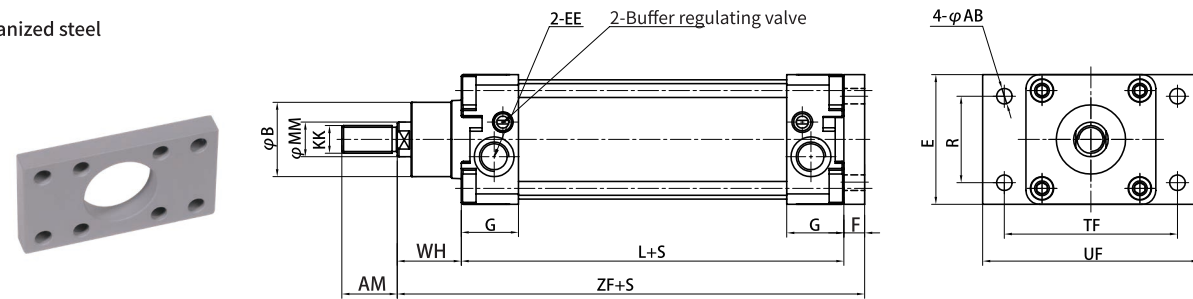

Diameter φ[mm]	AB	AM	B	E	EE	F	G	KK	L	MM	R	TF	UF	WH	ZF
32	7	22	30	47	G1/8	10	27.5	M10X1.25	94	12	32	64	80	26	130
40	9	24	35	53	G1/4	10	32	M12X1.25	105	16	36	72	90	30	145
50	9	32	40	65	G1/4	12	31	M16X1.5	106	20	45	90	110	37	155
63	9	32	45	75	G3/8	12	33	M16X1.5	121	20	50	100	125	37	170
80	12	40	45	95	G3/8	16	33	M20X1.5	128	25	63	126	154	46	190
100	14	40	55	115	G1/2	16	37	M20X1.5	138	25	75	150	185	51	205
125	16	54	60	140	G1/2	20	46	M27X2	160	32	90	180	220	65	245
160	18	72	65	180	G3/4	20	50	M36X2	180	40	115	230	280	80	280
200	22	72	75	220	G3/4	25	50	M36X2	180	40	135	270	320	95	300
250	26	84	90	280	G1	25	50	M42X2	200	50	165	330	390	105	320
320	28	96	110	350	G1	30	55	M48X2	220	63	200	400	470	120	360

TA front axle end pin seat type

Material: Galvanized steel

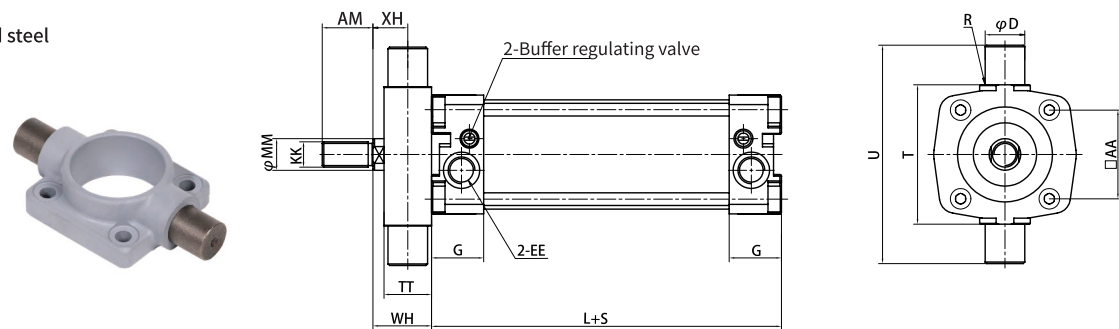

Diameter φ[mm]	AA	AM	D	EE	G	KK	L	MM	R	T	TT	U	WH	XN
32	32.5	22	12	G1/8	27.5	M10X1.25	94	12	1	50	20	74	26	16
40	38	24	16	G1/4	32	M12X1.25	105	16	1.5	63	24	95	30	18
50	46.5	32	16	G1/4	31	M16X1.5	106	20	1.6	75	28	107	37	23
63	56.5	32	20	G3/8	33	M16X1.5	121	20	1.6	90	28	130	37	23
80	72	40	20	G3/8	33	M20X1.5	128	25	1.6	110	28	150	46	32
100	89	40	25	G1/2	37	M20X1.5	138	25	2	132	38	182	51	32
125	110	54	25	G1/2	46	M27X2	160	32	2	160	50	210	65	40
160	140	72	32	G3/4	50	M36X2	180	40	2.5	200	50	264	80	55
200	175	72	32	G3/4	50	M36X2	180	40	2.5	250	50	314	95	70
250	220	84	40	G1	50	M42X2	200	50	3.2	320	60	400	105	75
320	270	96	50	G1	55	M48X2	220	63	3.2	400	70	500	120	85

-Installation method

TB Rear Form

Material: Galvanized steel

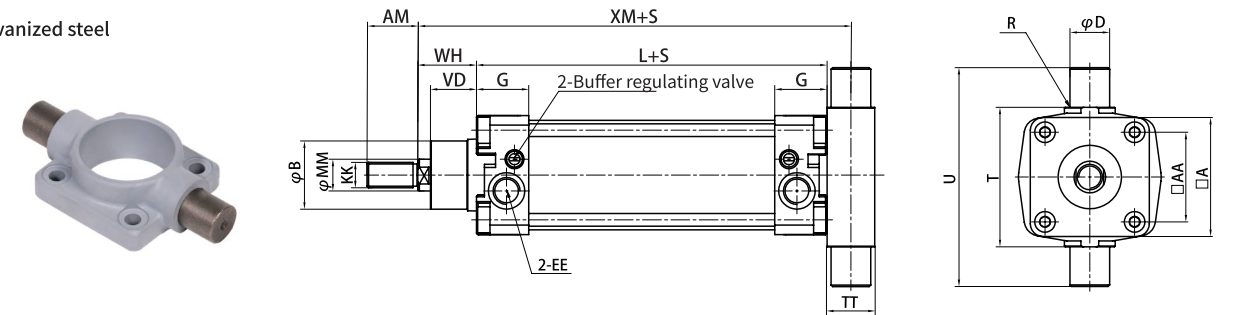

Diameter φ[mm]	A	AA	AM	B	D	EE	G	KK	L	MM	R	T	TT	U	VD	WH	XM
32	47	32.5	22	30	12	G1/8	27.5	M10X1.25	94	12	1	50	20	74	20	26	130
40	53	38	24	35	16	G1/4	32	M12X1.25	105	16	1.5	63	24	95	22	30	147
50	65	46.5	32	40	16	G1/4	31	M16X1.5	106	20	1.6	75	28	107	27	37	157
63	75	56.5	32	45	20	G3/8	33	M16X1.5	121	20	1.6	90	28	130	29	37	172
80	95	72	40	45	20	G3/8	33	M20X1.5	128	25	1.6	110	28	150	33	46	188
100	115	89	40	55	25	G1/2	37	M20X1.5	138	25	2	132	38	182	36	51	208
125	140	110	54	60	25	G1/2	46	M27X2	160	32	2	160	50	210	45	65	250
160	180	140	72	65	32	G3/4	50	M36X2	180	40	2.5	200	50	264	55	80	285
200	220	175	72	75	32	G3/4	50	M36X2	180	40	2.5	250	50	314	55	95	300
250	280	220	84	90	40	G1	50	M42X2	200	50	3.2	320	60	400	75	105	325
320	350	270	96	110	50	G1	55	M48X2	220	63	3.2	400	70	500	85	120	365

TC Middle Pin Form

The installation assembly can be installed in any position of the cylinder
Material: Galvanized steel

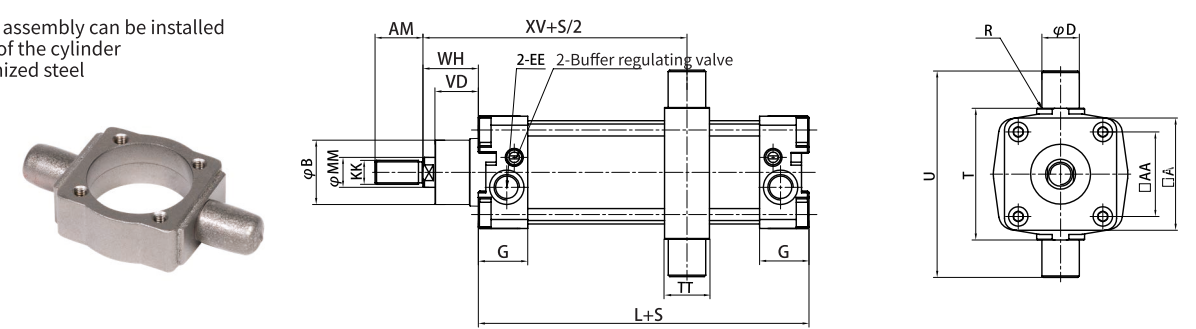

Diameter φ[mm]	A	AA	AM	B	D	EE	G	KK	L	MM	R	T	TT	U	VD	WH	XV
32	47	32.5	22	30	12	G1/8	27.5	M10X1.25	94	12	1	50	20	74	20	26	73
40	53	38	24	35	16	G1/4	32	M12X1.25	105	16	1.5	63	24	95	22	30	82.5
50	65	46.5	32	40	16	G1/4	31	M16X1.5	106	20	1.6	75	28	107	27	37	90
63	75	56.5	32	45	20	G3/8	33	M16X1.5	121	20	1.6	90	28	130	29	37	97.5
80	95	72	40	45	20	G3/8	33	M20X1.5	128	25	1.6	110	28	150	33	46	110
100	115	89	40	55	25	G1/2	37	M20X1.5	138	25	2	132	38	182	36	51	120
125	140	110	54	60	25	G1/2	46	M27X2	160	32	2	160	50	210	45	65	145
160	180	140	72	65	32	G3/4	50	M36X2	180	40	2.5	200	50	264	55	80	170
200	220	175	72	75	32	G3/4	50	M36X2	180	40	2.5	250	50	314	55	95	185
250	280	220	84	90	40	G1	50	M42X2	200	50	3.2	320	60	400	75	105	200
320	350	270	96	110	50	G1	55	M48X2	220	63	3.2	400	70	500	85	120	225

-Installation method

CA Single Ear Carrier Form

Material: Die-cast Aluminum

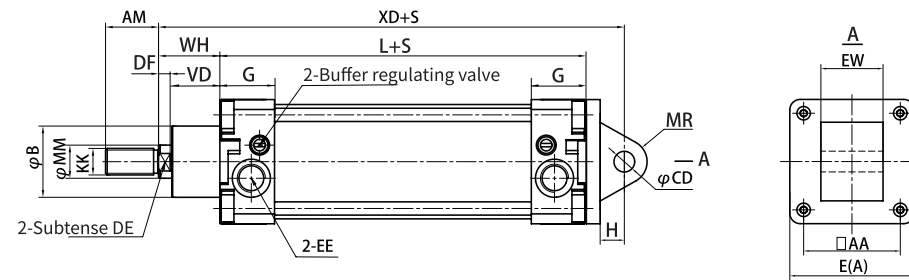

Diameter ϕ [mm]	AA	AM	B	CD	E(A)	EE	EW	G	H	KK	L	MM	MR	VD	WH	XD
32	32.5	22	30	10	47	G1/8	26	27.5	13	M10X1.25	94	12	10	20	26	142
40	38	24	35	12	53	G1/4	28	32	16	M12X1.25	105	16	13	22	30	160
50	46.5	32	40	12	65	G1/4	32	31	17	M16X1.5	106	20	16	27	37	170
63	56.5	32	45	16	75	G3/8	40	33	22	M16X1.5	121	20	18	29	37	190
80	72	40	45	16	95	G3/8	50	33	22	M20X1.5	128	25	18	33	46	210
100	89	40	55	20	115	G1/2	60	37	27	M20X1.5	138	25	23	36	51	230
125	110	54	60	25	140	G1/2	70	46	31	M27X2	160	32	30	45	65	275
160	140	72	65	30	180	G3/4	90	50	35.5	M36X2	180	40	32	55	80	315
200	175	72	75	30	220	G3/4	90	50	36	M36X2	180	40	35	55	95	335
250	220	84	90	40	280	G1	110	50	45	M42X2	200	50	45	75	105	365
320	270	96	110	45	350	G1	120	55	50	M48X2	220	63	54	85	120	410

CB Double-Ear Carrier Form

Material: Die-cast Aluminum

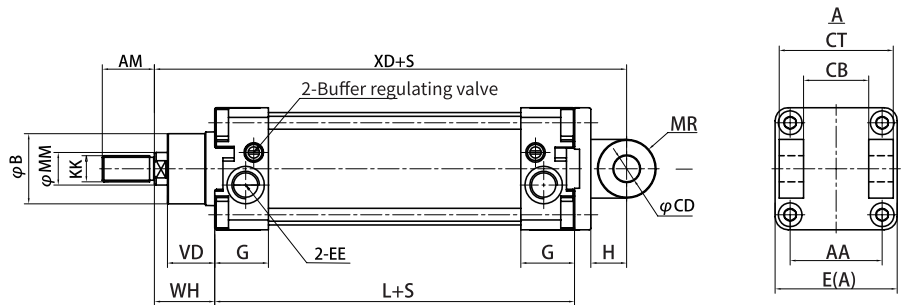

Diameter ϕ [mm]	AA	AM	B	CB	CD	CT	E(A)	EE	G	H	KK	L	MM	MR	VD	WH	XD
32	32.5	22	30	26	10	45	47	G1/8	27.5	13	M10X1.25	94	12	10	20	26	142
40	38	24	35	28	12	52	53	G1/4	32	16	M12X1.25	105	16	13	22	30	160
50	46.5	32	40	32	12	60	65	G1/4	31	17	M16X1.5	106	20	16	27	37	170
63	56.5	32	45	40	16	70	75	G3/8	33	22	M16X1.5	121	20	18	29	37	190
80	72	40	45	50	16	90	95	G3/8	33	22	M20X1.5	128	25	18	33	46	210
100	89	40	55	60	20	110	115	G1/2	37	27	M20X1.5	138	25	23	36	51	230
125	110	54	60	70	25	130	140	G1/2	45	31	M27X2	160	32	30	45	65	275
160	140	72	65	90	30	170	180	G3/4	50	35.5	M36X2	180	40	32	55	80	315
200	175	72	75	90	30	170	220	G3/4	50	36	M36X2	180	40	35	55	95	335
250	220	84	90	110	40	200	280	G1	50	45	M42X2	200	50	45	75	105	365
320	270	96	110	120	45	220	350	G1	55	50	M48X2	220	63	54	85	120	410

QGS...-E Series Locking Cylinder

Summary

The series is a QGS derived cylinder with cylinder diameter $\phi 40 \phi 200$ and piston rod locked in the terminal position against pressure drop as drop protection.

Product Features

- Optional with lock at either end or both ends;
- Unlocking method: automatic and manual;
- Anti corrosion: The cylinder barrel is made of high-quality aluminum alloy pipes, which have undergone hard anodizing treatment;
- Wear resistance: the piston rod is treated with Pre-rolled hardening, coated by hard inscription and fine grinding treatment, and has good rust resistance, wear resistance and other characteristics;
- Free of oil supply: use oil-containing alloy and special bearing liner.

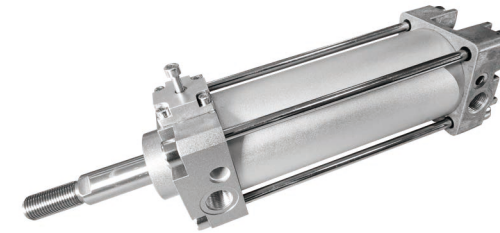

Diagram

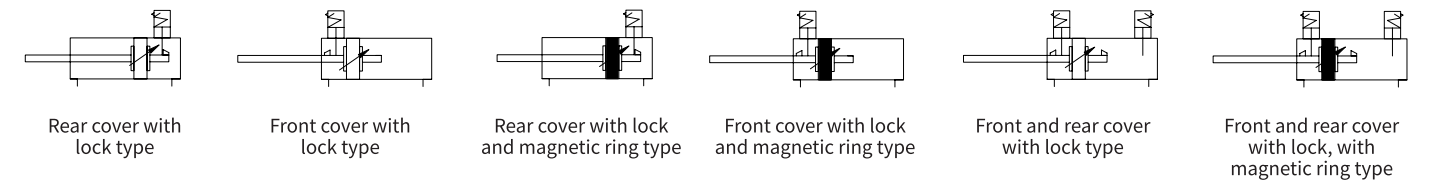

Standard stroke Table

Diameter ϕ [mm]	Standard Stroke																Max Stroke	Allowed Stroke			
	25	50	75	80	100	125	150	160	175	200	250	300	350	400	450	500			600	700	800
40																	1200	1800			
50																	1200	1800			
63																	1500	1800			
80																	1500	1800			
100	25	50	75	80	100	125	150	160	175	200	250	300	350	400	450	500	600	700	800	1500	1800
125																	1500	1800			
160																	1500	2000			
200																	1500	2000			

Note: Please contact us for any other special stroke

Structure Diagram[for example QGS-E3]

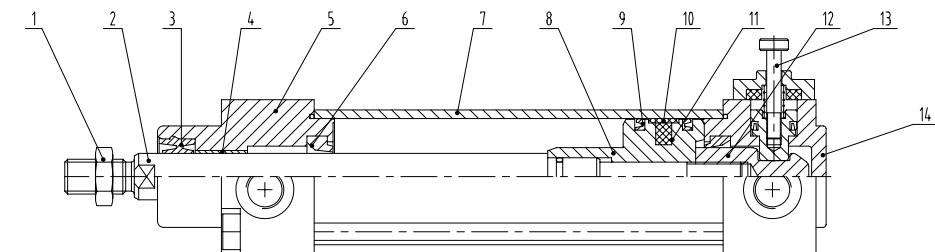

Standard Cylinder-with locking QGS									
[1]	Nut	Carbon Structural Steel	[6]	Magnet Ring	-	[11]	Hole Ring	NBR	
[2]	Piston Rod	Die-cast Aluminum	[7]	Buffer Column	-	[12]	Support Strap	POM	
[3]	Combination Ring	Polyurethane	[8]	Buffer ring	NBR	[13]	Locking Device Combination	-	
[4]	Guide Sleeve	Engineering Plastic	[9]	Cylinder Body	Anodized Refined Aluminum	[14]	Rear Cover	Die-cast Aluminum	
[5]	Front Cover	Die-cast Aluminum	[10]	Piston	Die-cast Aluminum				

Outline Dimension (QGS-E...)

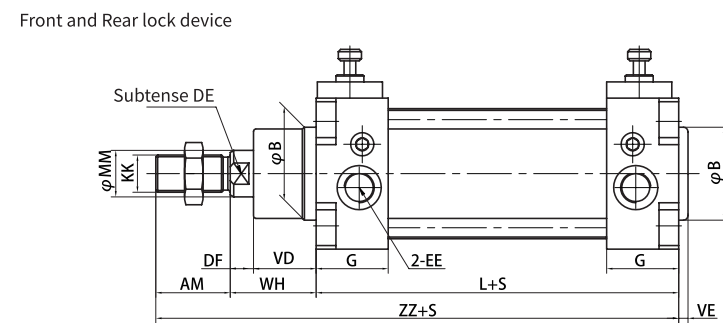
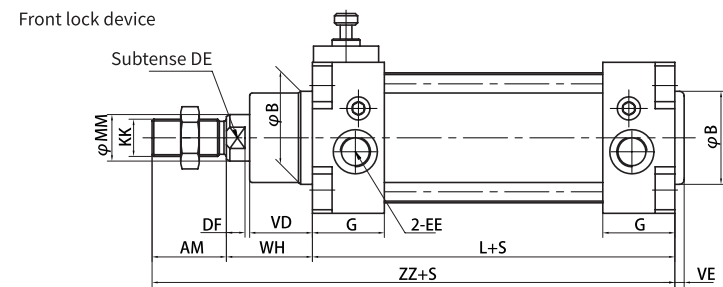
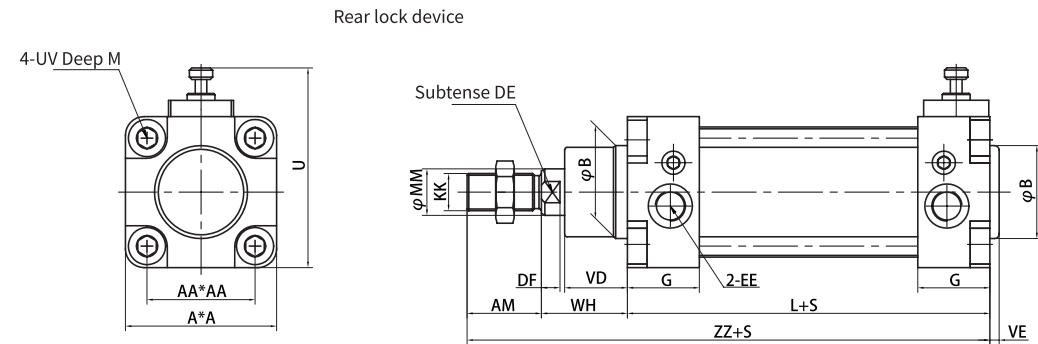

Diameter ϕ [mm]	A	AA	AM	B	DE	DF	EE	G	KK	L	M	MM	UV	VD	WH	VE	U	zz
40	53	38	24	35	14	7	G1/4	32	M12x1.25	105	10	16	M6	22	30	4	74	159
50	65	46.5	32	40	17	8	G1/4	31	M16x1.5	106	10	20	M8	27	37	4	86	175
63	75	56.5	32	45	17	8	G3/8	33	M16x1.5	121	11	20	M8	29	37	4	96	190
80	95	72	40	45	22	12	G3/8	33	M20x1.5	128	13	25	M10	33	46	4	117	214
100	115	89	40	55	22	13	G1/2	37	M20x1.5	138	13	25	M10	36	51	4	137	229
125	140	110	54	60	27	16	G1/2	46	M27x2	160	15	32	M12	45	65	6	172.5	279
160	180	140	72	65	36	18	G3/4	50	M36x2	180	20	40	M16	55	80	6	212.5	332
200	220	175	72	75	36	18	G3/4	50	M36x2	180	20	40	M16	65	95	6	252.5	347

Installation method

LB Axial foundation Type

Material: Galvanized steel

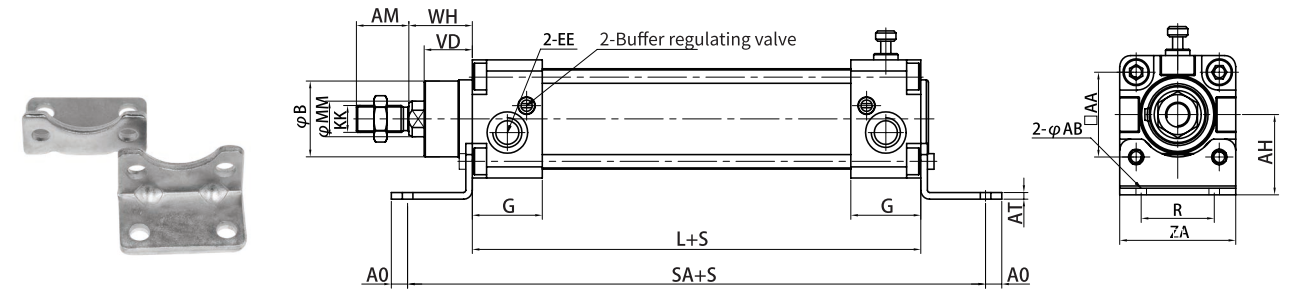

Diameter ϕ [mm]	AA	AB	AH	AM	A0	AT	B	EE	G	KK	L	MM	R	SA	VD	WH	ZA
40	38	9	36	24	10	5	35	G1/4	32	M12X1.25	105	16	36	161	22	30	53
50	46.5	9	45	32	10	6	40	G1/4	31	M16X1.5	106	20	45	169	27	37	62
63	56.5	9	50	32	12	6	45	G3/8	33	M16X1.5	121	20	50	185	29	37	75
80	72	12	63	40	17	8	45	G3/8	33	M20X1.5	128	25	63	210	33	46	94
100	89	14	71	40	20	8	55	G1/2	37	M20X1.5	138	25	75	220	36	51	112
125	110	16	90	54	20	11	60	G1/2	46	M27X2	160	32	90	250	45	65	140
160	140	18	115	72	20	12	65	G3/4	50	M36X2	180	40	115	300	55	80	180
200	175	22	135	72	30	15	75	G3/4	50	M36X2	180	40	135	320	55	95	220

FA Front Flange Type

Material: Galvanized steel

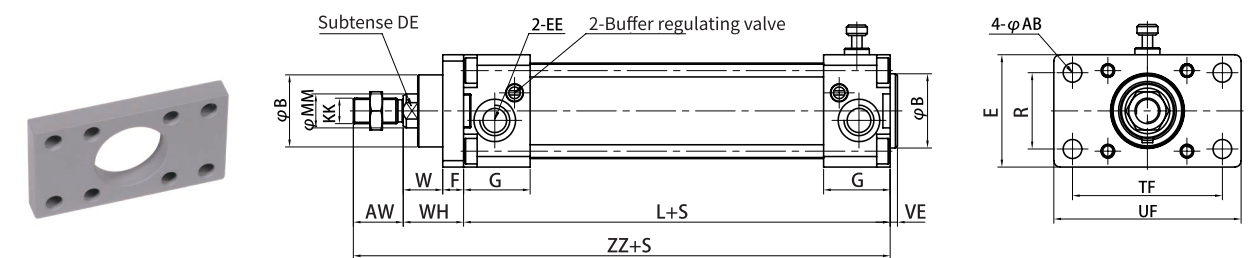

Diameter ϕ [mm]	AB	AM	B	DE	E	EE	F	G	KK	L	MM	R	TF	UF	VE	W	WH	zz
40	9	24	35	14	53	G1/4	10	32	M12X1.25	105	16	36	72	90	4	20	30	159
50	9	32	40	17	65	G1/4	12	31	M16X1.5	106	20	45	90	110	4	25	37	175
63	9	32	45	17	75	G3/8	12	33	M16X1.5	121	20	50	100	125	4	25	37	190
80	12	40	45	22	95	G3/8	16	33	M20X1.5	128	25	63	126	154	4	30	46	214
100	14	40	55	22	115	G1/2	16	37	M20X1.5	138	25	75	150	185	4	35	51	229
125	16	54	60	27	140	G1/2	20	46	M27X2	160	32	90	180	220	6	45	65	279
160	18	72	65	36	180	G3/4	20	50	M36X2	180	40	115	230	280	6	60	80	332
200	22	72	75	36	220	G3/4	25	50	M36X2	180	40	135	270	320	6	70	95	347

-Installation method

FB Rear Flange Type

Material: Galvanized steel

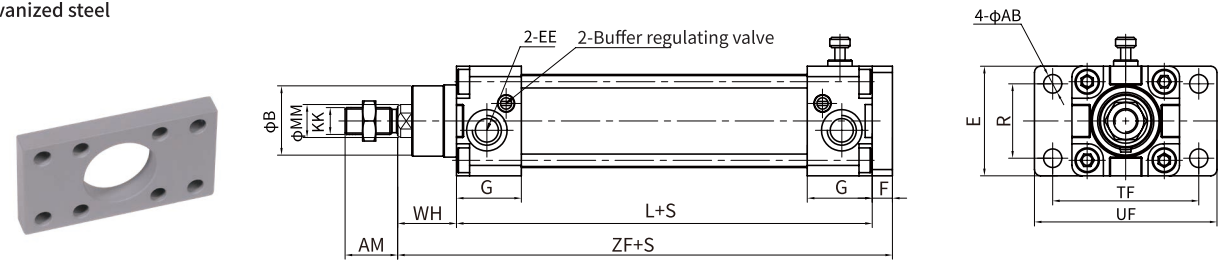

Diameter ϕ [mm]	AB	AM	B	E	EE	F	G	KK	L	MM	R	TF	UF	WH	ZF
40	9	24	35	53	G1/4	10	32	M12X1.25	105	16	36	72	90	30	145
50	9	32	40	65	G1/4	12	31	M16X1.5	106	20	45	90	110	37	155
63	9	32	45	75	G3/8	12	33	M16X1.5	121	20	50	100	125	37	170
80	12	40	45	95	G3/8	16	33	M20X1.5	128	25	63	126	154	46	190
100	14	40	55	115	G1/2	16	37	M20X1.5	138	25	75	150	185	51	205
125	16	54	60	140	G1/2	20	46	M27X2	160	32	90	180	220	65	245
160	18	72	65	180	G3/4	20	50	M36X2	180	40	115	230	280	80	280
200	22	72	75	220	G3/4	25	50	M36X2	180	40	135	270	320	95	300

TA Front Pin Form

Material: Galvanized steel

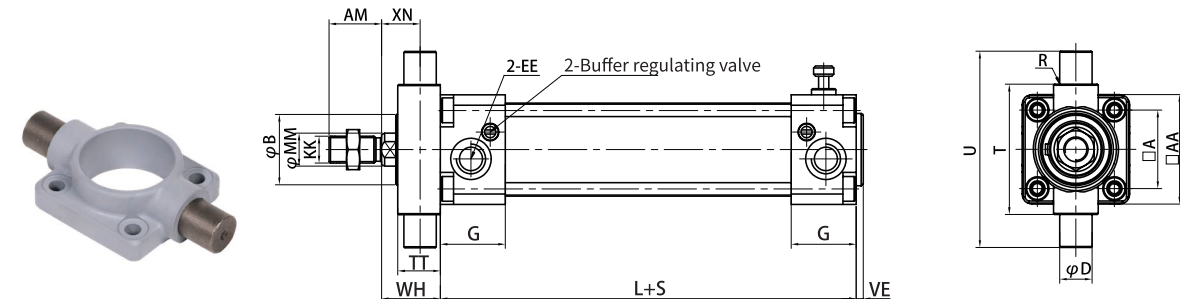

Diameter ϕ [mm]	A	AA	AM	B	D	EE	G	KK	L	MM	R	T	TT	U	VE	WH	XN
40	53	38	24	35	16	G1/4	32	M12X1.25	105	16	1.5	63	24	95	4	30	18
50	65	46.5	32	40	16	G1/4	31	M16X1.5	106	20	1.6	75	28	107	4	37	23
63	75	56.5	32	45	20	G3/8	33	M16X1.5	121	20	1.6	90	28	130	4	37	23
80	95	72	40	45	20	G3/8	33	M20X1.5	128	25	1.6	110	28	160	4	46	32
100	115	89	40	55	25	G1/2	37	M20X1.5	138	25	2	132	38	182	4	51	32
125	140	110	54	60	25	G1/2	46	M27X2	160	32	2	160	50	210	6	65	40
160	180	140	72	65	32	G3/4	50	M36X2	180	40	2.5	200	50	264	6	80	55
200	220	175	72	75	32	G3/4	50	M36X2	180	40	2.5	250	50	314	6	95	70

-Installation method

TC Middle Pin Form

The installation assembly can be installed in any position of the cylinder.
Material: Galvanized steel

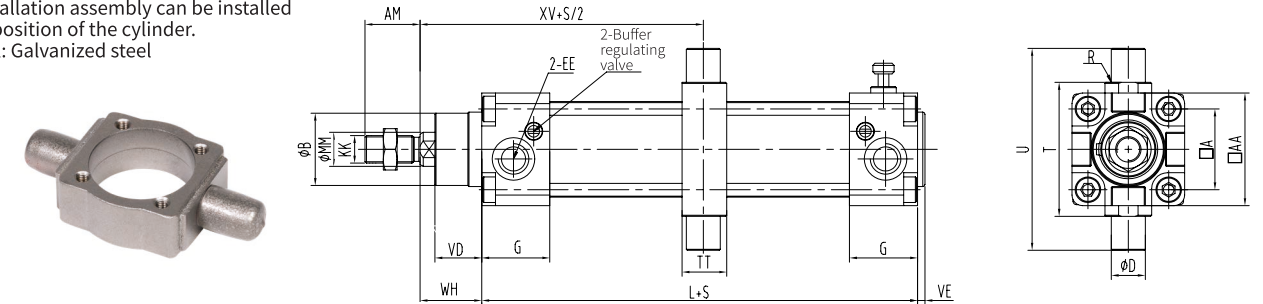

Diameter ϕ [mm]	A	AA	AM	B	D	EE	G	KK	L	MM	R	T	TT	U	VD	VE	WH	XV
40	53	38	24	35	16	G1/4	32	M12X1.25	105	16	1.5	63	24	95	22	4	30	82.5
50	65	46.5	32	40	16	G1/4	31	M16X1.5	106	20	1.6	75	28	107	27	4	37	90
63	75	56.5	32	45	20	G3/8	33	M16X1.5	121	20	1.6	90	28	130	29	4	37	97.5
80	95	72	40	45	20	G3/8	33	M20X1.5	128	25	1.6	110	28	160	33	4	46	110
100	115	89	40	55	25	G1/2	37	M20X1.5	138	25	2	132	38	182	36	4	51	120
125	140	110	54	60	25	G1/2	46	M27X2	160	32	2	160	50	210	45	6	65	145
160	180	140	72	65	32	G3/4	50	M36X2	180	40	2.5	200	50	264	55	6	80	170
200	220	175	72	75	32	G3/4	50	M36X2	180	40	2.5	250	50	314	55	6	95	185

CA Single Ear Carrier Form

Material: Die-cast Aluminum

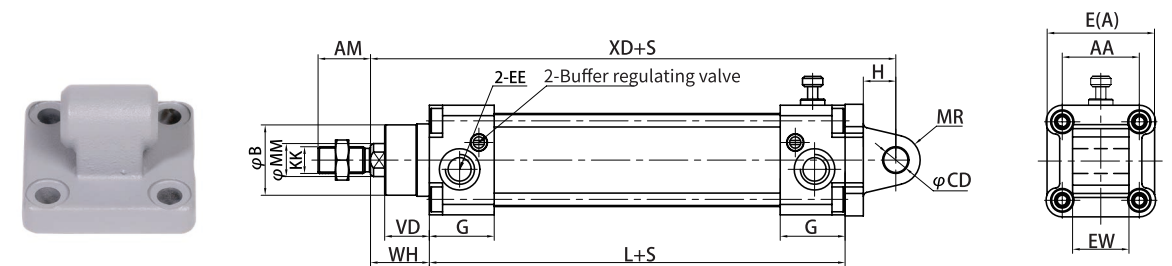

Diameter ϕ [mm]	AA	AM	B	CD	E(A)	EE	EW	G	H	KK	L	MM	MR	VD	WH	XD
32	32.5	22	30	10	47	G1/8	26	27.5	13	M10X1.25	94	12	10	20	26	142
40	38	24	35	12	53	G1/4	28	32	16	M12X1.25	105	16	13	22	30	160
50	46.5	32	40	12	65	G1/4	32	31	17	M16X1.5	106	20	16	27	37	170
63	56.5	32	45	16	75	G3/8	40	33	22	M16X1.5	121	20	18	29	37	190
80	72	40	45	16	95	G3/8	50	33	22	M20X1.5	128	25	18	33	46	210
100	89	40	55	20	115	G1/2	60	37	27	M20X1.5	138	25	23	36	51	230
125	110	54	60	25	140	G1/2	70	46	31	M27X2	160	32	30	45	65	275
160	140	72	65	30	180	G3/4	90	50	35.5	M36X2	180	40	32	55	80	315
200	175	72	75	30	220	G3/4	90	50	36	M36X2	180	40	35	55	95	335
250	220	84	90	40	280	G1	110	50	45	M42X2	200	50	45	75	105	365
320	270	96	110	45	350	G1	120	55	50	M48X2	220	63	54	85	120	410

-Installation method

CB Double-ear Carrier Form

Material: Die-cast Aluminum

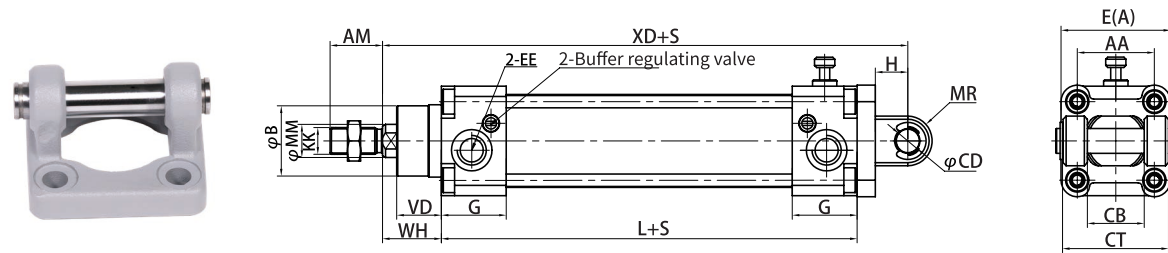

Diameter ϕ [mm]	AA	AM	B	CB	CD	CT	E(A)	EE	G	H	KK	L	MM	MR	VD	WH	XD
32	32.5	22	30	26	10	45	47	G1/8	27.5	13	M10X1.25	94	12	10	20	26	142
40	38	24	35	28	12	52	53	G1/4	32	16	M12X1.25	105	16	13	22	30	160
50	46.5	32	40	32	12	60	65	G1/4	31	17	M16X1.5	106	20	16	27	37	170
63	56.5	32	45	40	16	70	75	G3/8	33	22	M16X1.5	121	20	18	29	37	210
80	72	40	45	50	16	90	95	G3/8	33	22	M20X1.5	128	25	18	33	46	210
100	89	40	55	60	20	110	115	G1/2	37	27	M20X1.5	138	25	23	26	51	230
125	110	54	60	70	25	130	140	G1/2	45	31	M27X2	160	32	30	45	65	275
160	140	72	65	90	30	170	180	G3/4	50	35.5	M36X2	180	40	32	55	80	315
200	175	72	75	90	30	170	220	G3/4	50	36	M36X2	180	40	35	55	95	335
250	220	84	90	110	40	200	280	G1	50	45	M42X2	200	50	45	75	105	365
320	270	96	110	120	45	220	350	G1	55	50	M48X2	220	63	54	85	120	410



QGS...-L Series range-adjustable cylinder

Summary

This series is QGS derived cylinder, QGS cylinder piston rod stroke is designed to form an adjustable stroke cylinder, cylinder diameter ϕ 32 ϕ 160.

Product features

- Adjustment mode: one-side manual adjustment;
- Travel adjustment range: 0-50mm.

Diagram

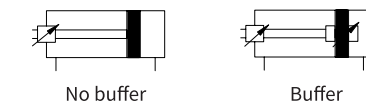

Structure diagram

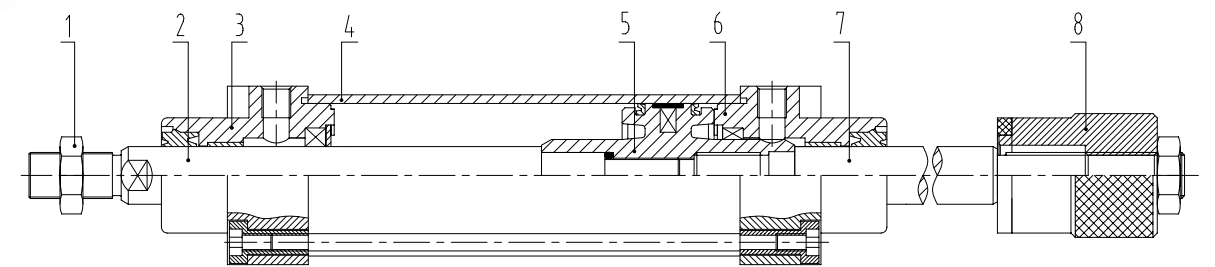

Standard cylinder—Stroke adjustment QGSL								
[1]	Nut	Carbon Structural Steel	[4]	Cylinder Body	Anodized Refined Aluminum alloy	[7]	Adjustable piston rod	Improved Carbon Structural Steel
[2]	Hole with Ring	NBR	[5]	Piston	Carbon Structural Steel	[8]	Regulating handle	Improved Carbon Structural Steel
[3]	Front cover	Die-cast Aluminum	[6]	Rear cover	Die-cast Aluminum			

Outline Dimension

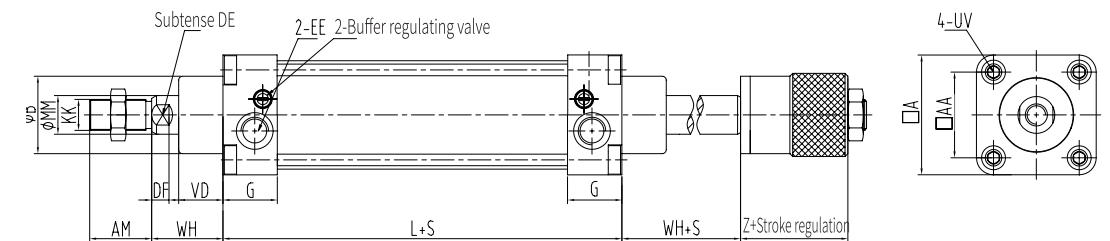

Diameter ϕ [mm]	A	AA	AM	B	DE	DF	EE	G	KK	L	MM	UV	VD	WH	Z
32	47	32.5	22	30	10	5	G1/8	27.5	M10×1.25	94	12	M6	20	26	24
40	53	38	24	35	14	7	G1/4	32	M12×1.25	105	16	M6	22	30	30
50	65	46.5	32	40	17	8	G1/4	31	M16×1.5	106	20	M8	27	37	35
63	75	56.5	32	45	17	8	G3/8	33	M16×1.5	121	20	M8	29	37	35
80	95	72	40	45	22	12	G3/8	33	M20×1.5	128	25	M10	33	46	40
100	115	89	40	55	22	13	G1/2	37	M20X1.5	138	25	M10	36	51	40
125	140	110	54	61	27	16	G1/2	46	M27X2	160	32	M12	45	65	46
160	180	140	72	80	36	18	G3/4	50	M36X2	180	45	M16	55	80	60

Installation method

LB Axial foundation Type

Material: Galvanized steel

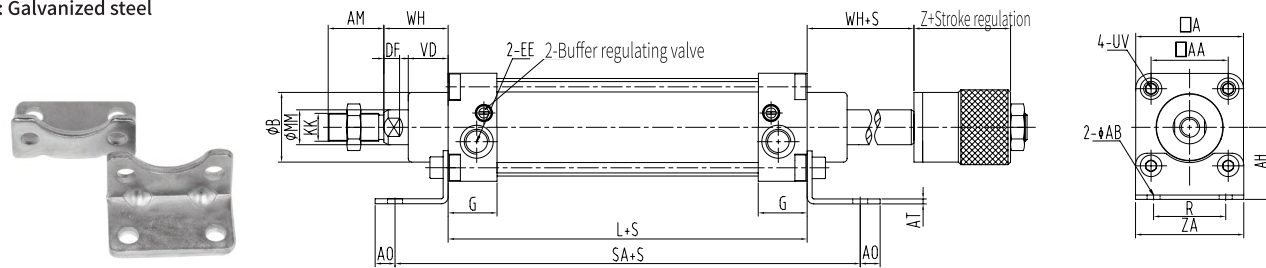

Diameter φ[mm]	A	AA	AB	AH	AM	A0	AT	B	DF	EE	G	KK	L	MM	R	SA	UV	VD	WH	Z	ZA
32	47	32.5	7	32	22	8	4	30	5	G1/8	27.5	M10X1.25	94	12	32	142	M6	20	26	24	47
40	53	38	9	36	24	10	5	35	7	G1/4	32	M12X1.25	105	16	36	161	M6	22	30	30	53
50	65	46.5	9	45	32	10	6	40	8	G1/4	31	M16X1.5	106	20	45	169	M8	27	37	35	62
63	75	56.5	9	50	32	12	6	45	8	G3/8	33	M16X1.5	121	20	50	185	M8	29	37	35	75
80	95	72	12	63	40	17	8	45	12	G3/8	33	M20X1.5	128	25	63	210	M10	33	46	40	94
100	115	89	14	71	40	20	8	55	13	G1/2	37	M20X1.5	138	25	75	220	M10	36	51	40	112
125	140	110	16	90	54	20	11	60	16	G1/2	46	M27X2	160	32	90	250	M12	45	65	46	140
160	180	140	18	115	72	20	12	65	18	G3/4	50	M36X2	180	40	115	300	M16	55	80	60	180

FA Front Flange Type

Material: Galvanized steel

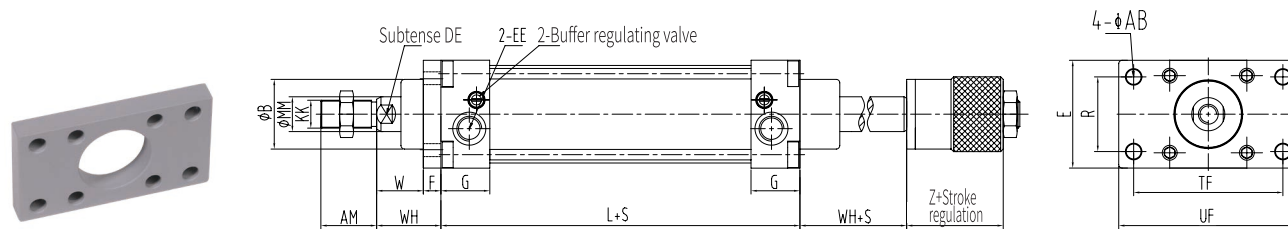

Diameter φ[mm]	AB	AM	B	DE	E	EE	F	G	KK	L	MM	R	TF	UF	W	WH	Z
32	7	22	30	10	47	G1/8	10	27.5	M10X1.25	94	12	32	64	80	16	26	24
40	9	24	35	14	53	G1/4	10	32	M12X1.25	105	16	36	72	90	20	30	30
50	9	32	40	17	65	G1/4	12	31	M16X1.5	106	20	45	90	110	25	37	35
63	9	32	45	17	75	G3/8	12	33	M16X1.5	121	20	50	100	125	25	37	35
80	12	40	45	22	95	G3/8	16	33	M20X1.5	128	25	63	126	154	30	46	40
100	14	40	55	22	115	G1/2	16	37	M20X1.5	138	25	75	150	185	35	51	40
125	16	54	60	27	140	G1/2	20	46	M27X2	160	32	90	180	220	45	65	46
160	18	72	65	36	180	G3/4	20	50	M36X2	180	40	115	230	280	60	80	60

-Installation method

TA front Axle end pin seat type

Material: Galvanized steel

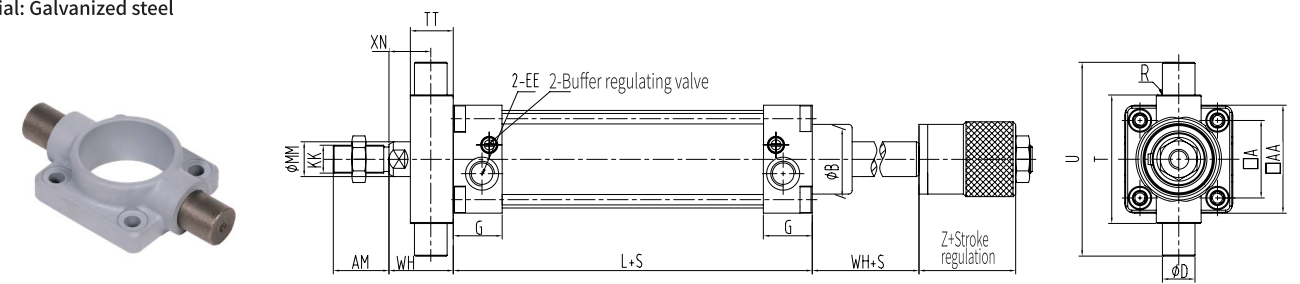

Diameter φ[mm]	A	AA	AM	B	D	EE	G	KK	L	MM	R	T	TT	U	WH	XN	Z
32	47	32.5	22	30	12	G1/8	27.5	M10X1.25	94	12	1	50	20	74	26	16	24
40	53	38	24	35	16	G1/4	32	M12X1.25	105	16	1.5	63	24	95	30	18	30
50	65	46.5	32	40	16	G1/4	31	M16X1.5	106	20	1.6	75	28	107	37	23	35
63	75	56.5	32	45	20	G3/8	33	M16X1.5	121	20	1.6	90	28	130	37	23	35
80	95	72	40	45	20	G3/8	33	M20X1.5	128	25	1.6	110	28	150	46	32	40
100	115	89	40	55	25	G1/2	37	M20X1.5	138	25	2	132	38	182	51	32	40
125	140	110	54	60	25	G1/2	46	M27X2	160	32	2	160	50	210	65	40	46
160	180	140	72	65	32	G3/4	50	M36X2	180	40	2.5	200	50	264	80	55	60

TB Rear Form

Material: Galvanized steel

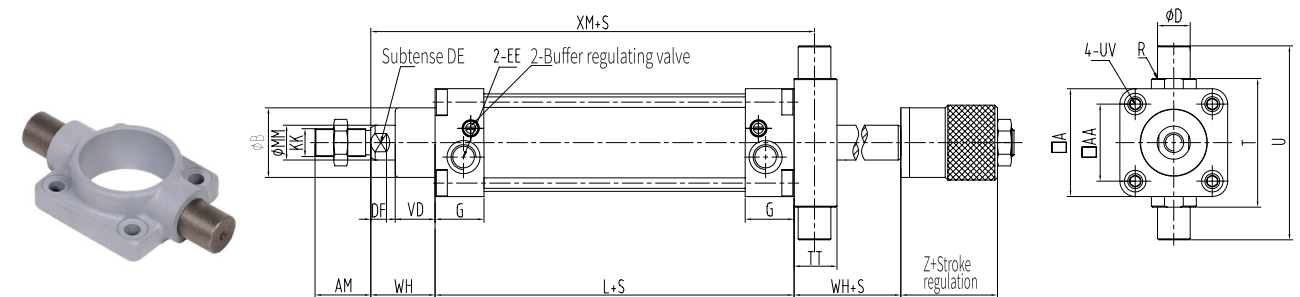

Diameter φ[mm]	A	AA	AM	B	D	DE	DF	EE	G	KK	L	MM	R	T	TT	U	UV	VD	WH	XM	Z
32	47	32.5	22	30	12	10	5	G1/8	27.5	M10X1.25	94	12	1	50	20	74	M6	20	26	130	24
40	53	38	24	35	16	14	7	G1/4	32	M12X1.25	105	16	1.5	63	24	95	M6	22	30	147	30
50	65	46.5	32	40	16	17	8	G1/4	31	M16X1.5	106	20	1.6	75	28	107	M8	27	37	157	35
63	75	56.5	32	45	20	17	8	G3/8	33	M16X1.5	121	20	1.6	90	28	130	M8	29	37	172	35
80	95	72	40	45	20	22	12	G3/8	33	M20X1.5	128	25	1.6	110	28	150	M10	33	46	188	40
100	115	89	40	55	25	22	13	G1/2	37	M20X1.5	138	25	2	132	38	182	M10	36	51	208	40
125	140	110	54	60	25	27	16	G1/2	46	M27X2	160	32	2	160	50	210	M12	45	65	250	46
160	180	140	72	65	32	36	18	G3/4	50	M36X2	180	40	2.5	200	50	264	M16	55	80	285	60

QGS...2 Series Common Double-Acting Cylinder

Summary

This series is QGS derived double piston rod cylinder, used for both ends, namely piston two ends of two piston rod, bidirectional action, thrust and pull the same direction, speed, stroke, cylinder diameter ϕ 32 ϕ 320, for the installation of external block.

Product features

- Anti corrosion: The cylinder barrel is made of high-quality aluminum alloy pipes, which have undergone hard anodizing treatment;
- Wear resistance: The piston rod is pre rolled and hardened, plated with hard chromium and finely ground, and has good rust prevention, wear resistance, and other characteristics;
- Free of oil supply: use oil-containing alloy and special bearing liner;
- Diversified brackets: Multiple fixed and non fixed brackets for customers to choose from.



Diagram

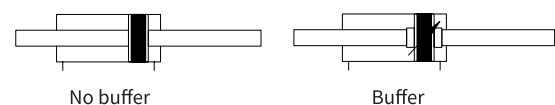

Structure Diagram

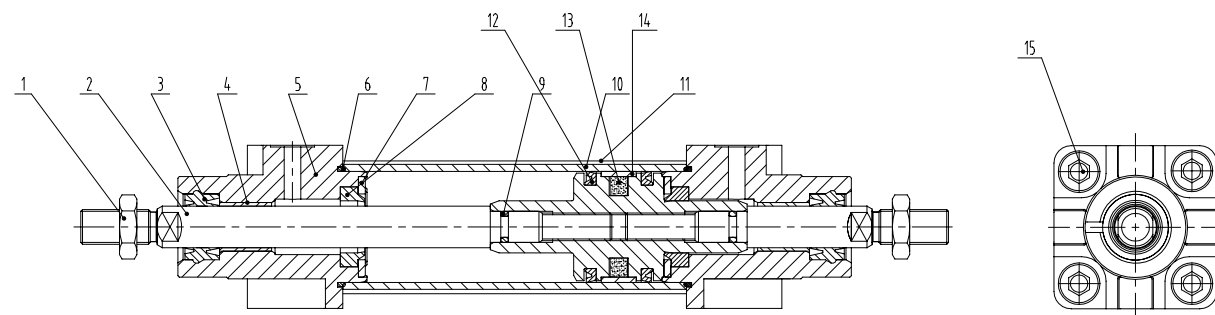

Standard cylinder-double piston rod QGS...2		
Serial Number	Name	Material
[1]	Nut	Carbon Structural Steel
[2]	Piston Rod	Improved Carbon Structural Steel
[3]	Axis Ring	Polyurethane
[4]	Guide Sleeve	Engineering Plastic
[5]	Front cover	Die-cast Aluminum
[6]	Rectangular Ring	NBR
[7]	Tablet Compressing	
[8]	Buffer Ring	NBR

Standard cylinder-double piston rod QGS...2		
Serial Number	Name	Material
[9]	O Ring	NBR
[10]	Cylinder Body	Anodized refined aluminum alloy
[11]	Connect Rod	Improved Carbon Structural Steel
[12]	Hole with Ring	NBR
[13]	Magnet Ring	-
[14]	Support Ring	POM
[15]	Pull-rod Nut	Carbon Structural Steel

Outline Dimension

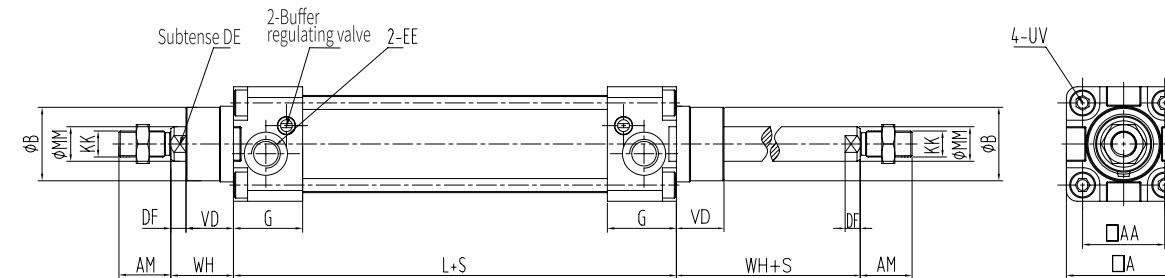

Diameter ϕ [mm]	A	AA	AM	B	DE	DF	EE	G	KK	L	MM	UV	VD	WH
32	47	32.5	22	30	10	5	G1/8	27.5	M10×1.25	94	12	M6	20	26
40	53	38	24	35	14	7	G1/4	32	M12×1.25	105	16	M6	22	30
50	65	46.5	32	40	17	8	G1/4	31	M16×1.5	106	20	M8	27	37
63	75	56.5	32	45	17	8	G3/8	33	M16×1.5	121	20	M8	29	37
80	95	72	40	45	22	12	G3/8	33	M20×1.5	128	25	M10	33	46
100	115	89	40	55	22	13	G1/2	37	M20×1.5	138	25	M10	36	51
125	140	110	54	60	27	16	G1/2	46	M27×2	160	32	M12	45	65
160	180	140	72	65	36	18	G3/4	50	M36×2	180	40	M16	55	80
200	220	175	72	75	36	18	G3/4	50	M36×2	180	40	M16	65	95
250	280	220	84	90	42	20	G1	50	M42×2	200	50	M20	75	105
320	350	270	96	110	55	20	G1	55	M48×2	220	63	M24	85	120

Installation method

LB Axial foundation Type

Material: Galvanized steel

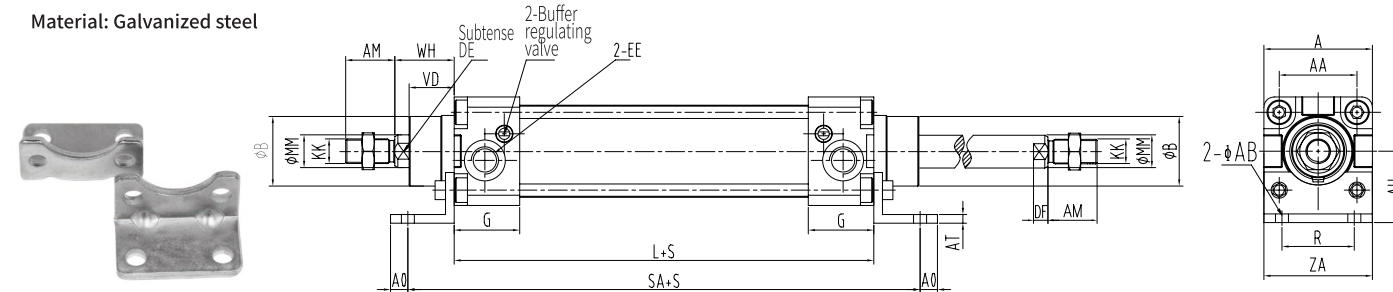

Diameter ϕ [mm]	A	AA	AB	AH	AM	A0	AT	B	DE	DF	EE	G	KK	L	MM	R	SA	VD	WH	ZA
32	47	32.5	7	32	22	8	4	30	10	5	G1/8	27.5	M10X1.25	94	12	32	142	20	26	47
40	53	38	9	36	24	10	5	35	14	7	G1/4	32	M12X1.25	105	16	36	161	22	30	53
50	65	46.5	9	45	32	10	6	40	17	8	G1/4	31	M16X1.5	106	20	45	169	27	37	62
63	75	56.5	9	50	32	12	6	45	17	8	G3/8	33	M16X1.5	121	20	50	185	29	37	75
80	95	72	12	63	40	17	8	45	22	12	G3/8	33	M20X1.5	128	25	63	210	33	46	94
100	115	89	14	71	40	20	8	55	22	13	G1/2	37	M20X1.5	138	25	75	220	36	51	112
125	140	110	16	90	54	20	11	60	27	16	G1/2	46	M27X2	160	32	90	250	45	65	140
160	180	140	18	115	72	20	12	65	36	18	G3/4	50	M36X2	180	40	115	300	55	80	180
200	220	175	22	135	72	30	15	75	36	18	G3/4	50	M36X2	180	40	135	320	55	95	220
250	280	220	26	165	84	35	20	90	42	20	G1	50	M42X2	200	50	165	350	75	105	280
320	350	270	33	200	96	40	23	105	55	20	G1	55	M48X2	220	63	200	390	85	120	350

-Installation method

FA Front Flange Type

Material: Galvanized steel

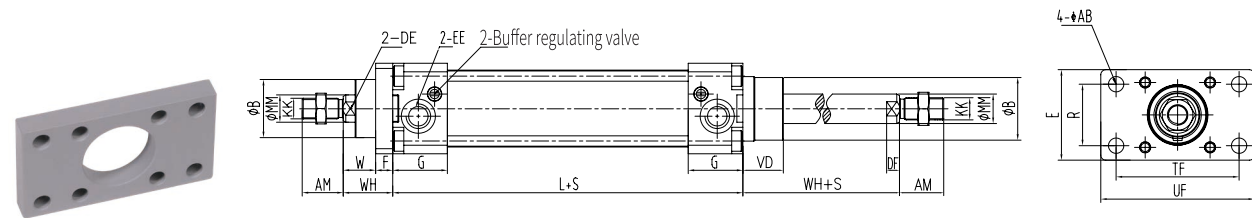

Diameter φ[mm]	AB	AM	B	DE	DF	E	EE	F	G	KK	L	MM	R	TF	UF	VD	W	WH
32	7	22	30	10	5	47	G1/8	10	27.5	M10X1.25	94	12	32	64	80	20	16	26
40	9	24	35	14	7	53	G1/4	10	32	M12X1.25	105	16	36	72	90	22	20	30
50	9	32	40	17	8	65	G1/4	12	31	M16X1.5	106	20	45	90	110	27	25	37
63	9	32	45	17	8	75	G3/8	12	33	M16X1.5	121	20	50	100	125	29	25	37
80	12	40	45	22	12	95	G3/8	16	33	M20X1.5	128	25	63	126	154	33	30	46
100	14	40	55	22	13	115	G1/2	16	37	M20X1.5	138	25	75	150	185	36	35	51
125	16	54	60	27	16	140	G1/2	20	46	M27X2	160	32	90	180	220	45	45	65
160	18	72	65	36	18	180	G3/4	20	50	M36X2	180	40	115	230	280	55	60	80
200	22	72	75	36	18	220	G3/4	25	50	M36X2	180	40	135	270	320	55	70	95
250	26	84	90	42	20	280	G1	25	50	M42X2	200	50	165	330	390	75	80	105
320	28	96	110	55	20	350	G1	30	55	M48X2	220	63	200	400	470	85	90	120

TA Front axle end pin seat type

Material: Galvanized steel

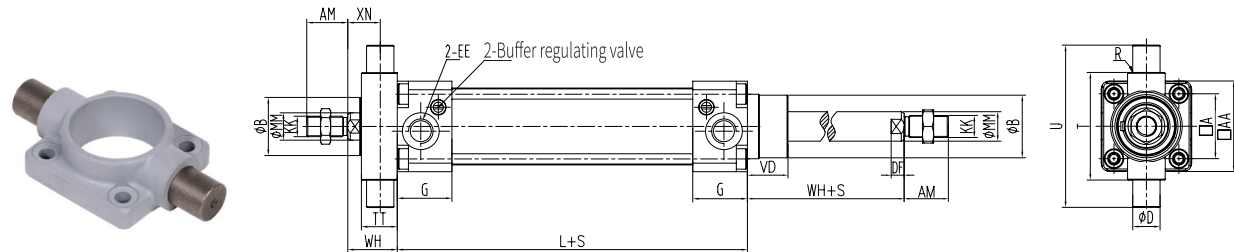

Diameter φ[mm]	A	AA	AM	B	D	DE	DF	EE	G	KK	L	MM	R	T	TT	U	VD	WH	XM
32	47	32.5	22	30	12	5	G1/8	27.5	M10X1.25	94	12	1	50	20	74	20	26	130	
40	53	38	24	35	16	7	G1/4	32	M12X1.25	105	16	1.5	63	24	95	22	30	147	
50	65	46.5	32	40	16	8	G1/4	31	M16X1.5	106	20	1.6	75	28	107	27	37	157	
63	75	56.5	32	45	20	8	G3/8	33	M16X1.5	121	20	1.6	90	28	130	29	37	172	
80	95	72	40	45	20	12	G3/8	33	M20X1.5	128	25	1.6	110	28	160	33	46	188	
100	115	89	40	55	25	13	G1/2	37	M20X1.5	138	25	2	132	38	182	36	51	208	
125	140	110	54	60	25	16	G1/2	46	M27X2	160	32	2	160	50	210	45	65	250	
160	180	140	72	65	32	18	G3/4	50	M36X2	180	40	2.5	200	50	264	55	80	285	
200	220	175	72	75	32	18	G3/4	50	M36X2	180	40	2.5	250	50	314	55	95	300	
250	280	220	84	90	40	20	G1	50	M42X2	200	50	3.2	320	60	400	75	105	325	
320	350	270	96	110	50	20	G1	55	M48X2	220	63	3.2	400	70	500	85	120	365	

-Installation method

TC Middle Pin Form

The installation assembly can be installed in any position of the cylinder. Material: Galvanized steel

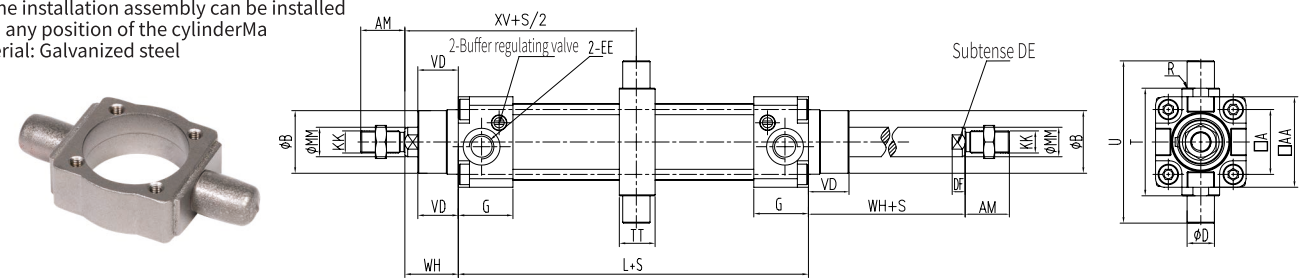

Diameter φ[mm]	A	AA	AM	B	D	DE	DF	EE	G	KK	L	MM	R	T	TT	U	VD	WH	XV
32	47	32.5	22	30	12	10	5	G1/8	27.5	M10X1.25	94	12	1	50	20	74	20	26	73
40	53	38	24	35	16	14	7	G1/4	32	M12X1.25	105	16	1.5	63	24	95	22	30	82.5
50	65	46.5	32	40	16	17	8	G1/4	31	M16X1.5	106	20	1.6	75	28	107	27	37	90
63	75	56.5	32	45	20	17	8	G3/8	33	M16X1.5	121	20	1.6	90	28	130	29	37	97.5
80	95	72	40	45	20	22	12	G3/8	33	M20X1.5	128	25	1.6	110	28	160	33	46	110
100	115	89	40	55	25	22	13	G1/2	37	M20X1.5	138	25	2	132	38	182	36	51	120
125	140	110	54	60	25	27	16	G1/2	46	M27X2	160	32	2	160	50	210	45	65	145
160	180	140	72	65	32	36	18	G3/4	50	M36X2	180	40	2.5	200	50	264	55	80	170
200	220	175	72	75	32	36	18	G3/4	50	M36X2	180	40	2.5	250	50	314	55	95	185
250	280	220	84	90	40	42	20	G1	50	M42X2	200	50	3.2	320	60	400	75	105	200
320	350	270	96	110	50	55	20	G1	55	M48X2	220	63	3.2	400	70	500	85	120	225

TB Rear Form

Material: Galvanized steel

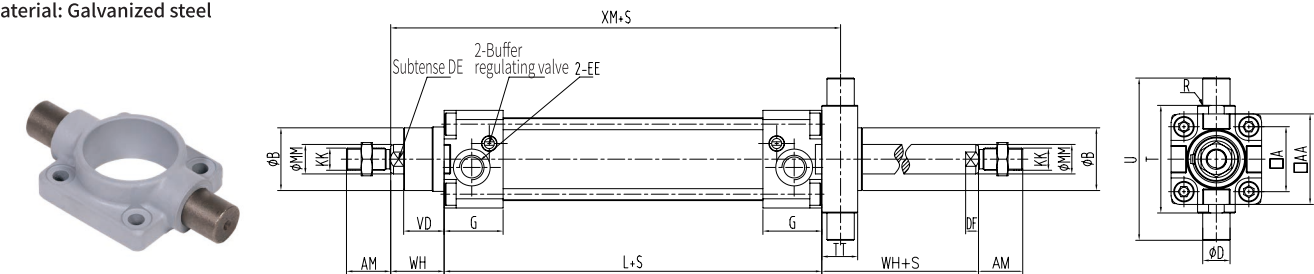

Diameter φ[mm]	A	AA	AM	B	D	DE	DF	EE	G	KK	L	MM	R	T	TT	U	VD	WH	XM
32	47	32.5	22	30	12	10	5	G1/8	27.5	M10X1.25	94	12	1	50	20	74	20	26	130
40	53	38	24	35	16	14	7	G1/4	32	M12X1.25	105	16	1.5	63	24	95	22	30	147
50	65	46.5	32	40	16	17	8	G1/4	31	M16X1.5	106	20	1.6	75	28	107	27	37	157
63	75	56.5	32	45	20	17	8	G3/8	33	M16X1.5	121	20	1.6	90	28	130	29	37	172
80	95	72	40	45	20	22	12	G3/8	33	M20X1.5	128	25	1.6	110	28	160	33	46	188
100	115	89	40	55	25	22	13	G1/2	37	M20X1.5	138	25	2	132	38	182	36	51	208
125	140	110	54	60	25	27	16	G1/2	46	M27X2	160	32	2	160	50	210	45	65	250
160	180	140	72	65	32	36	18	G3/4	50	M36X2	180	40	2.5	200	50	264	55	80	285
200	220	175	72	75	32	36	18	G3/4	50	M36X2	180	40	2.5	250	50	314	55	95	300
250	280	220	84	90	40	42	20	G1	50	M42X2	200	50	3.2	320	60	400	75	105	325
320	350	270	96	110	50	55	20	G1	55	M48X2	220	63	3.2	400	70	500	85	120	365

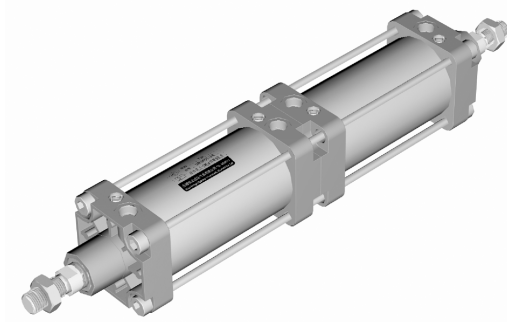

QGS...P Series Multi-position Cylinder

Summary

The series for QGS derived cylinder, by two QGS ordinary type single piston rod cylinder combination, multiple cylinder piston rod has four positions along the direction of the piston rod fixed at one end, when the cylinder any input on the working source, the piston rod is in one of the four positions, travel is S1 and S2 respectively, the cylinder can make the two piston rod in the opposite direction at the same time.

Product features

- Piston seal adopts special-type two-way sealing structure, compact size and oil storage function;
- Multiple locations can be located;
- There are many fixed methods available for customers to choose from.

Diagram

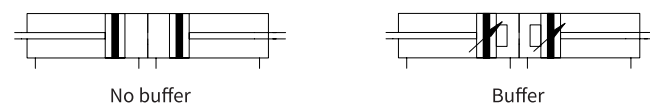

Structure Diagram

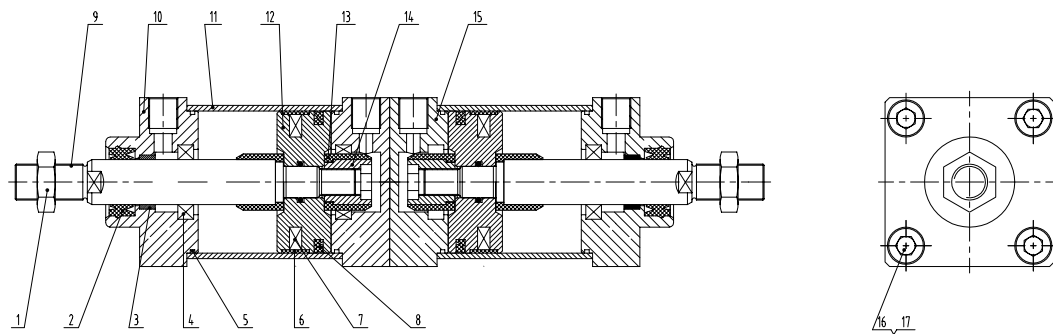

Standard cylinder-The multi bit cylinder QGS...-P		
Serial Number	Name	Material
[1]	Nut	Carbon Structural Steel
[2]	Combination Dust proof ring	Polyurethane
[3]	Guide Sleeve	Engineering Plastic
[4]	Cushion Collar	NBR
[5]	O Ring	NBR
[6]	Wearing Ring	POM
[7]	Magnet Ring	-
[8]	Hole with Ring	NBR
[9]	Piston Rod	Improved Carbon Structural Steel

Standard cylinder-The multi bit cylinder QGS...-P		
Serial Number	Name	Material
[10]	Front cover	Die-cast Aluminum
[11]	Cylinder Body	Die-cast Aluminum
[12]	Piston	Die-cast Aluminum
[13]	Buffer Ring	NBR
[14]	Buffer Screws	-
[15]	Rear Cover	Die-cast Aluminum
[16]	Pull-rod Nut	Carbon Structural Steel
[17]	Connect Rod	Improved Carbon Structural Steel

Outline Dimension

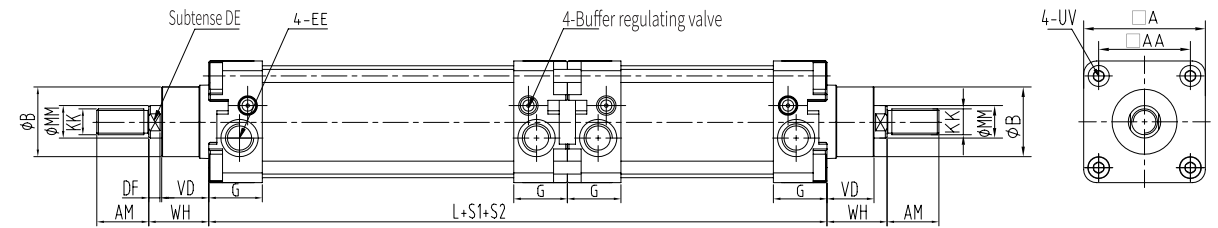

Diameter ϕ [mm]	A	AA	AM	B	DE	DF	EE	G	KK	L	MM	UV	VD	WH
32	47	32.5	22	30	10	5	G1/8	27.5	M10×1.25	188	12	M6	20	26
40	53	38	24	35	14	7	G1/4	32	M12×1.25	210	16	M6	22	30
50	65	46.5	32	40	17	8	G1/4	31	M16×1.5	212	20	M8	27	37
63	75	56.5	32	40	17	8	G3/8	33	M16×1.5	242	20	M8	29	37
80	95	72	40	45	22	12	G3/8	33	M20×1.5	256	25	M10	33	46
100	115	89	40	55	22	13	G1/2	37	M20×1.5	276	25	M10	36	51

Installation method

LB Axial foundation Type

Material: Galvanized steel

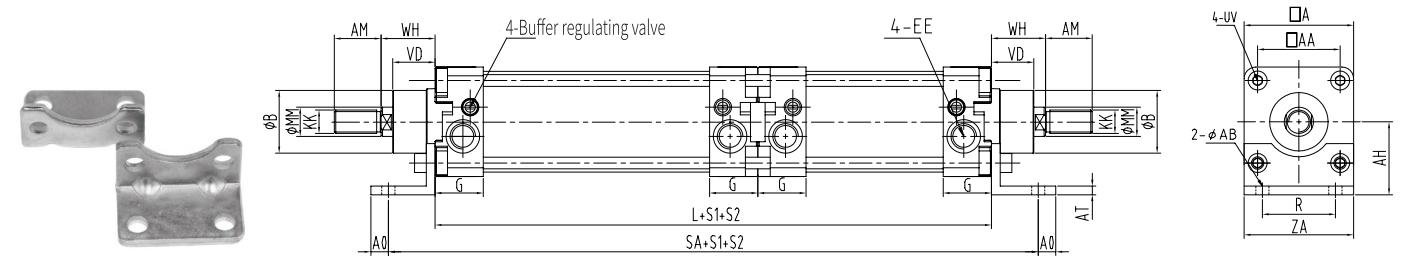

Diameter ϕ [mm]	A	AA	AB	AH	AM	A0	AT	B	EE	G	KK	L	MM	R	SA	UV	VD	WH	ZA
32	47	32.5	7	32	22	8	4	30	G1/8	27.5	M10X1.25	94	12	32	142	M6	20	26	47
40	53	38	9	36	24	10	5	35	G1/4	32	M12X1.25	105	16	36	161	M6	22	30	53
50	65	46.5	9	45	32	10	6	40	G1/4	31	M16X1.5	106	20	45	169	M8	27	37	62
63	75	56.5	9	50	32	12	6	45	G3/8	33	M16X1.5	121	20	50	185	M8	29	37	75
80	95	72	12	63	40	17	8	45	G3/8	33	M20X1.5	128	25	63	210	M10	33	46	94
100	115	89	14	71	40	20	8	55	G1/2	37	M20X1.5	138	25	75	220	M10	36	51	112

-Installation method

FA Front Flange Type

Material: Galvanized steel

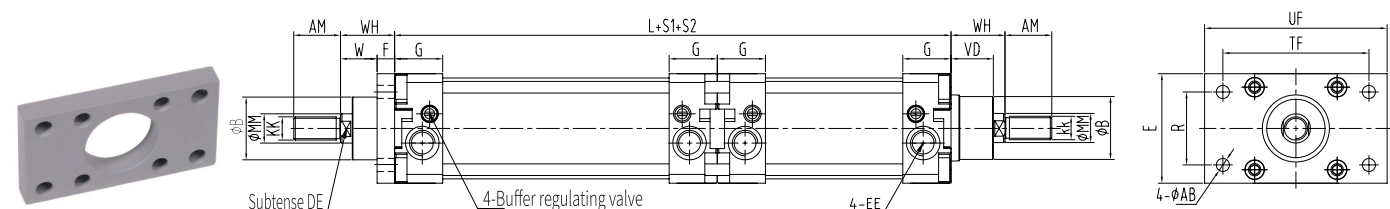

Diameter φ[mm]	AB	AM	B	DE	E	EE	F	G	KK	L	MM	R	TF	UF	W	WH
32	7	22	30	10	47	G1/8	10	27.5	M10X1.25	94	12	32	64	80	16	26
40	9	24	35	14	53	G1/4	10	32	M12X1.25	105	16	36	72	90	20	30
50	9	32	40	17	65	G1/4	12	31	M16X1.5	106	20	45	90	110	25	37
63	9	32	45	17	75	G3/8	12	33	M16X1.5	121	20	50	100	125	25	37
80	12	40	45	22	95	G3/8	16	33	M20X1.5	128	25	63	126	154	30	46
100	14	40	55	22	115	G1/2	16	37	M20X1.5	138	25	75	150	185	35	51

TA front axle end pin seat type

Material: Galvanized steel

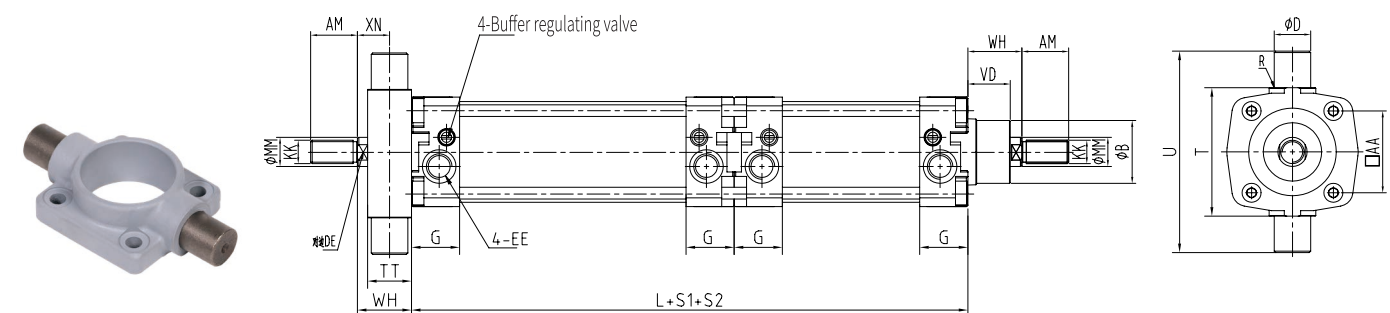

Diameter φ[mm]	AA	AM	B	D	DE	EE	G	KK	L	MM	R	T	TT	U	VD	WH	XN
32	32.5	22	30	12	10	G1/8	27.5	M10X1.25	94	12	1	50	20	74	20	26	16
40	38	24	35	16	14	G1/4	32	M12X1.25	105	16	1.5	63	24	95	22	30	18
50	46.5	32	40	16	17	G1/4	31	M16X1.5	106	20	1.6	75	28	107	27	37	23
63	56.5	32	45	20	17	G3/8	33	M16X1.5	121	20	1.6	90	28	130	29	37	23
80	72	40	45	20	22	G3/8	33	M20X1.5	128	25	1.6	110	28	160	33	46	32
100	89	40	55	25	22	G1/2	37	M20X1.5	138	25	2	132	38	182	36	51	32

-Installation method

TC Rear Form

Material: Galvanized steel

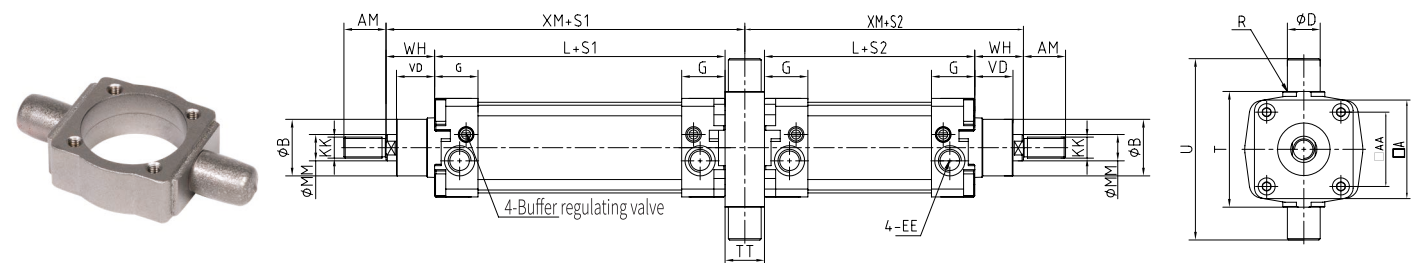

Diameter φ[mm]	A	AA	AM	B	D	EE	G	KK	L	MM	R	T	TT	U	VD	WH	XM
32	47	32.5	22	30	12	G1/8	27.5	M10X1.25	94	12	1	50	20	74	20	26	130
40	53	38	24	35	16	G1/4	32	M12X1.25	105	16	1.5	63	24	95	22	30	147
50	65	46.5	32	40	16	G1/4	31	M16X1.5	106	20	1.6	75	28	107	27	37	157
63	75	56.5	32	45	20	G3/8	33	M16X1.5	121	20	1.6	90	28	130	29	37	172
80	95	72	40	45	20	G3/8	33	M20X1.5	128	25	1.6	110	28	160	33	46	188
100	115	89	40	55	25	G1/2	37	M20X1.5	138	25	2	132	38	182	36	51	208

QGS...-J Series Cylinder

Summary

This series is a series cylinder derived from QGS, consisting of two QGS series cylinders with the same cylinder diameter ϕA dual piston rod double acting buffer cylinder with a piston rod connection of 32-100, its output tension is twice that of the QGS series cylinder, and the thrust is the sum of the thrust and tension of the QGS series cylinder, which can be used as a booster cylinder.

Product features

- Booster cylinder;
- Smooth adjustment of cylinder buffer;
- The piston seal adopts a special-shaped bidirectional sealing structure, with compact size and oil storage function;
- Multiple fixed methods for customers to choose from.

Diagram

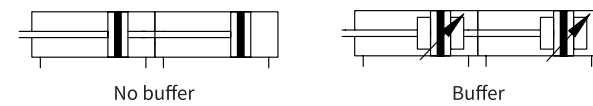

Structure Diagram

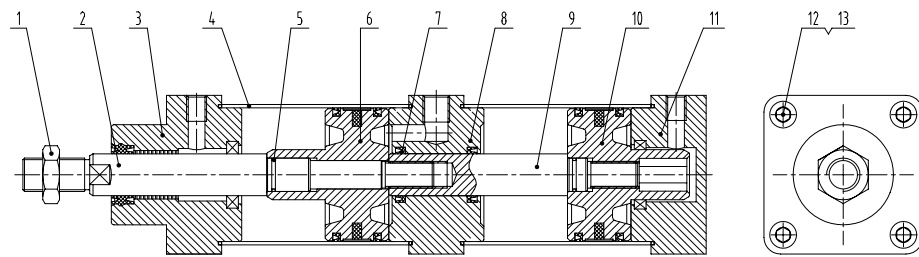

Standard Cylinder- -Series Cylinder		
Serial Number	Name	Material
[1]	Nut	Structural Carbon Steel
[2]	Piston Rod A	Improved Carbon Structural Steel
[3]	Front cover	Die-cast Aluminum
[4]	Cylinder Body	Die-cast Aluminum
[5]	O Ring	NBR
[6]	Piston A	Die-cast Aluminum
[7]	Hole with Ring	NBR

Standard Cylinder- -Series Cylinder		
Serial Number	Name	Material
[8]	Middle Cover	Die-cast Aluminum
[9]	Piston rod B	Improved Carbon Structural Steel
[10]	Plunger B	Die-cast Aluminum
[11]	Rear Cover	Die-cast Aluminum
[12]	Pull-Rod Nut	Carbon structural steel
[13]	Connect Rod	Improved Carbon Structural Steel

Outline Dimension

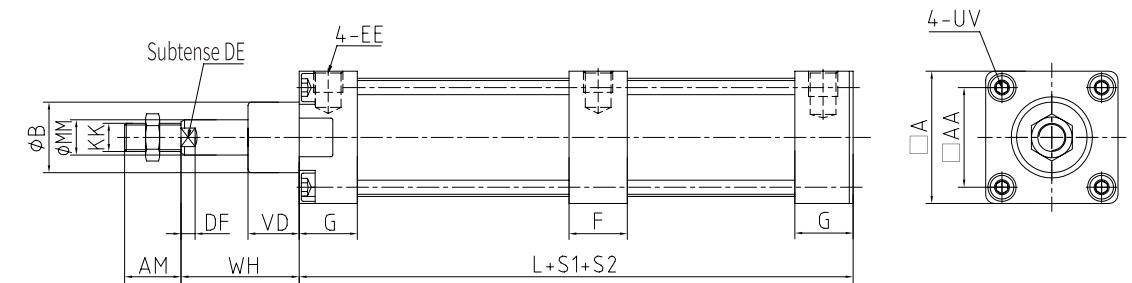

Diameter ϕ [mm]	A	AA	AM	B	DE	DF	EE	G	KK	L	MM	UV	VD	WH
32	47	32.5	22	30	10	5	G1/8	27.5	M10×1.25	188	12	M6	20	26
40	53	38	24	35	14	7	G1/4	32	M12×1.25	210	16	M6	22	30
50	65	46.5	32	40	17	8	G1/4	31	M16×1.5	212	20	M8	27	37
63	75	56.5	32	45	17	8	G3/8	33	M16×1.5	242	20	M8	29	37
80	95	72	40	45	22	12	G3/8	33	M20×1.5	256	25	M10	33	46
100	115	89	40	55	22	13	G1/2	37	M20×1.5	276	25	M10	36	51

Installation method

LB Axial foundation Type

Material: Galvanized steel

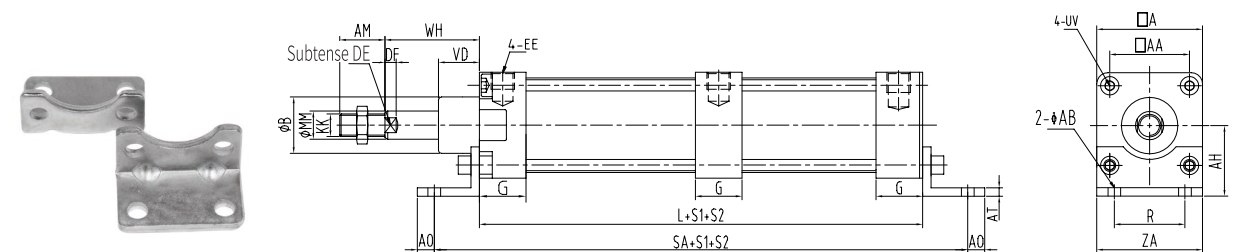

Diameter ϕ [mm]	A	AA	AB	AH	AM	A0	AT	B	DE	DF	EE	G	KK	L	MM	R	SA	UV	VD	WH	ZA
32	47	32.5	7	32	22	8	4	30	10	5	G1/8	27.5	M10X1.25	94	12	32	142	M6	20	26	47
40	53	38	9	36	24	10	5	35	14	7	G1/4	32	M12X1.25	105	16	36	161	M6	22	30	53
50	65	46.5	9	45	32	10	6	40	17	8	G1/4	31	M16X1.5	106	20	45	169	M8	27	37	62
63	75	56.5	9	50	32	12	6	45	17	8	G3/8	33	M16X1.5	121	20	50	185	M8	29	37	75
80	95	72	12	63	40	17	8	45	22	12	G3/8	33	M20X1.5	128	25	63	210	M10	33	46	94
100	115	89	14	71	40	20	8	55	22	13	G1/2	37	M20X1.5	138	25	75	220	M10	36	51	112

-Installation method

FA Front Flange Type

Material: Galvanized steel

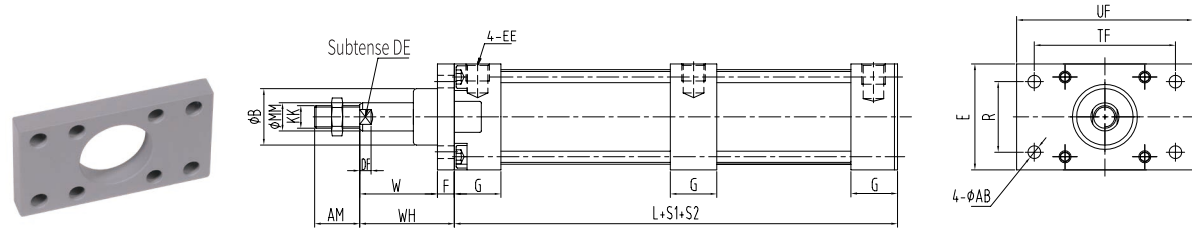

Diameter ϕ (mm)	AB	AM	B	DE	DF	E	EE	F	G	KK	L	MM	R	TF	UF	W	WH
32	7	22	30	10	5	47	G1/8	10	27.5	M10X1.25	94	12	32	64	80	16	26
40	9	24	35	14	7	53	G1/4	10	32	M12X1.25	105	16	36	72	90	20	30
50	9	32	40	17	8	65	G1/4	12	31	M16X1.5	106	20	45	90	110	25	37
63	9	32	45	17	8	75	G3/8	12	33	M16X1.5	121	20	50	100	125	25	37
80	12	40	45	22	12	95	G3/8	16	33	M20X1.5	128	25	63	126	154	30	46
100	14	40	55	22	13	115	G1/2	16	37	M20X1.5	138	25	75	150	185	35	51

FB Rear Flange Type

Material: Galvanized steel

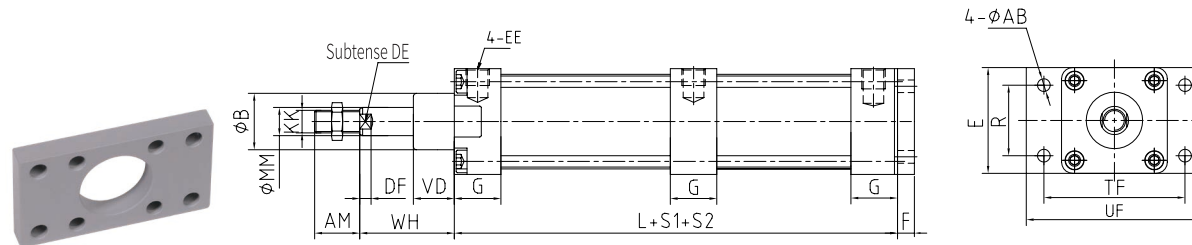

Diameter ϕ (mm)	AB	AM	B	DE	DF	E	EE	F	G	KK	L	MM	R	TF	UF	VD	WH
32	7	22	30	10	5	47	G1/8	10	27.5	M10X1.25	94	12	32	64	80	20	26
40	9	24	35	14	7	53	G1/4	10	32	M12X1.25	105	16	36	72	90	22	30
50	9	32	40	17	8	65	G1/4	12	31	M16X1.5	106	20	45	90	110	27	37
63	9	32	45	17	8	75	G3/8	12	33	M16X1.5	121	20	50	100	125	29	37
80	12	40	45	22	12	95	G3/8	16	33	M20X1.5	128	25	63	126	154	33	46
100	14	40	55	22	13	115	G1/2	16	37	M20X1.5	138	25	75	150	185	36	51

-Installation method

TA front axle end pin seat type

Material: Galvanized steel

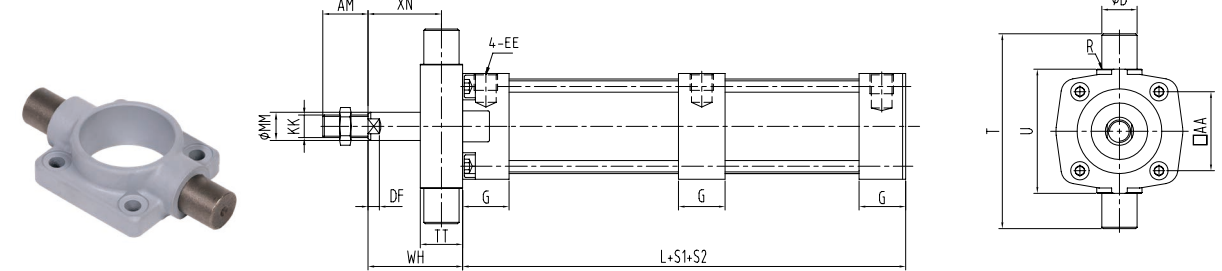

Diameter ϕ (mm)	AA	AM	D	DF	EE	G	KK	L	MM	R	T	TT	U	WH	XN
32	32.5	22	12	5	G1/8	27.5	M10X1.25	94	12	1	50	20	74	26	16
40	38	24	16	7	G1/4	32	M12X1.25	105	16	1.5	63	24	95	30	18
50	46.5	32	16	8	G1/4	31	M16X1.5	106	20	1.6	75	28	107	37	23
63	56.5	32	20	8	G3/8	33	M16X1.5	121	20	1.6	90	28	130	37	23
80	72	40	20	12	G3/8	33	M20X1.5	128	25	1.6	110	28	160	46	32
100	89	40	25	13	G1/2	37	M20X1.5	138	25	2	132	38	182	51	32

TB Rear Form

Material: Galvanized steel

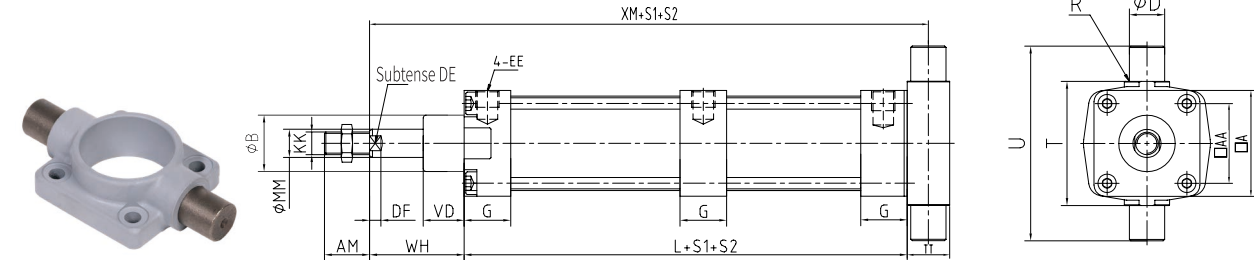

Diameter ϕ (mm)	A	AA	AM	B	D	DE	DF	EE	G	KK	L	MM	R	T	TT	U	VD	WH	XM
32	47	32.5	22	30	12	10	5	G1/8	27.5	M10X1.25	94	12	1	50	20	74	20	26	130
40	53	38	24	35	16	14	7	G1/4	32	M12X1.25	105	16	1.5	63	24	95	22	30	147
50	65	46.5	32	40	16	17	8	G1/4	31	M16X1.5	106	20	1.6	75	28	107	27	37	157
63	75	56.5	32	45	20	17	8	G3/8	33	M16X1.5	121	20	1.6	90	28	130	29	37	172
80	95	72	40	45	20	22	12	G3/8	33	M20X1.5	128	25	1.6	110	28	160	33	46	188
100	115	89	40	55	25	22	13	G1/2	37	M20X1.5	138	25	2	132	38	182	36	51	208

-Installation method

CA Single Ear Carrier Form

Material: Die-cast Aluminum

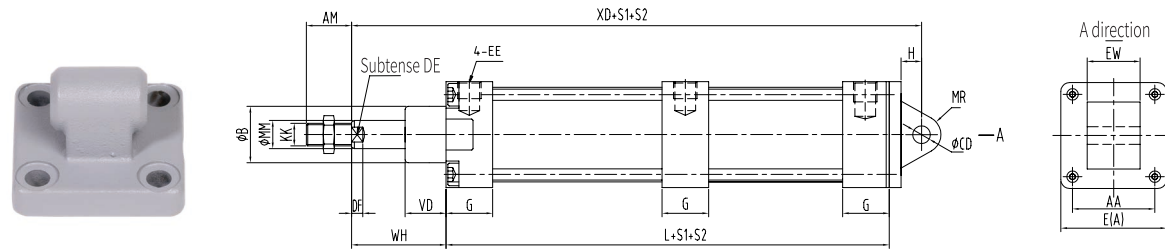

Diameter ϕ (mm)	AA	AM	B	DE	DF	E(A)	EE	EW	G	H	KK	L	MM	MR	VD	WH	XD
32	32.5	22	30	10	5	47	G1/8	26	27.5	13	M10X1.25	94	12	10	20	26	142
40	38	24	35	14	7	53	G1/4	28	32	16	M12X1.25	105	16	13	22	30	160
50	46.5	32	40	17	8	65	G1/4	32	31	17	M16X1.5	106	20	16	27	37	170
63	56.5	32	45	17	8	75	G3/8	40	33	22	M16X1.5	121	20	18	29	37	190
80	72	40	45	22	12	95	G3/8	50	33	22	M20X1.5	128	25	18	33	46	210
100	89	40	55	22	13	115	G1/2	60	37	27	M20X1.5	138	25	23	36	51	230

CB Double-ear Carrier Form

Material: Die-cast Aluminum

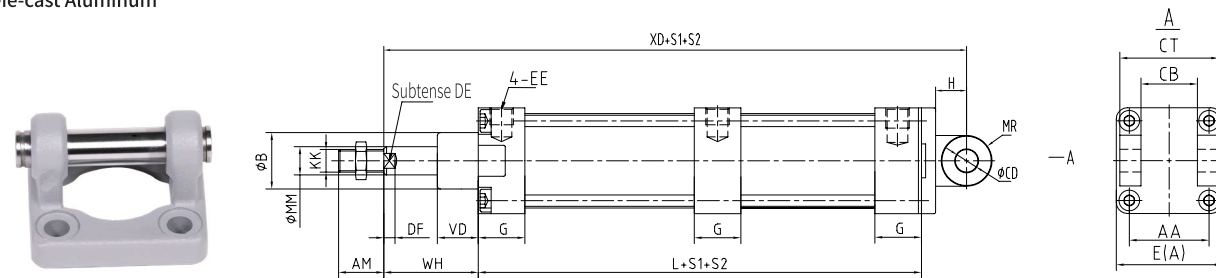

Diameter ϕ (mm)	AA	AM	B	CB	CD	CT	DE	DF	E(A)	EE	G	H	KK	L	MM	MR	VD	WH	XD
32	32.5	22	30	26	10	45	10	5	47	G1/8	27.5	13	M10X1.25	94	12	10	20	26	142
40	38	24	35	28	12	52	14	7	53	G1/4	32	16	M12X1.25	105	16	13	22	30	160
50	46.5	32	40	32	12	60	17	8	65	G1/4	31	17	M16X1.5	106	20	16	27	37	170
63	56.5	32	45	40	16	70	17	8	75	G3/8	33	22	M16X1.5	121	20	18	29	37	210
80	72	40	45	50	16	90	22	12	95	G3/8	33	22	M20X1.5	128	25	18	33	46	210
100	89	40	55	60	20	110	22	13	115	G1/2	37	27	M20X1.5	138	25	23	26	51	230

Peripherals overview

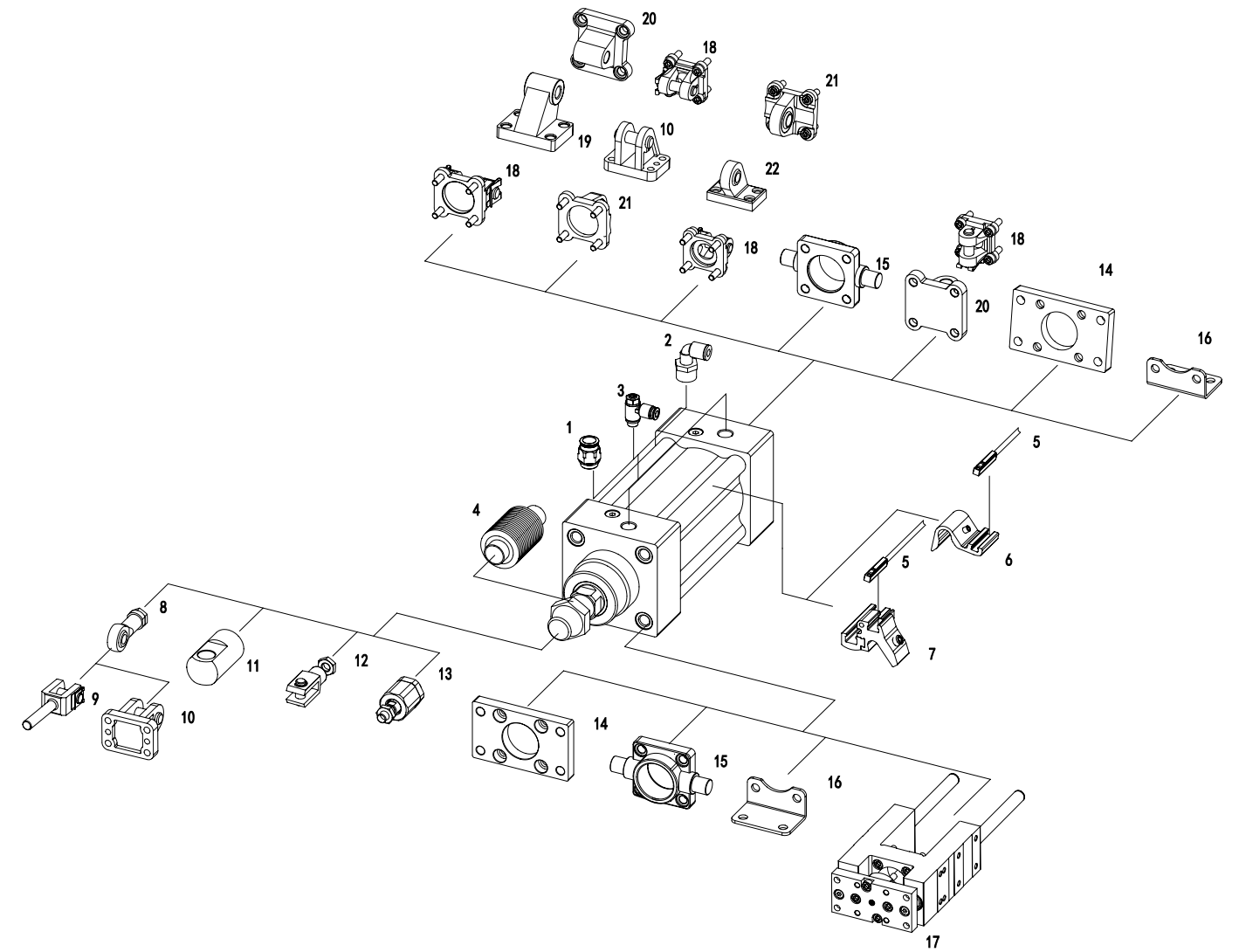



Mounting attachments and accessories			
Serial Number	Code Name	Name	Description
1	PC	Push-in fitting	For connecting compressed air tubing with standard O.D.
2	PL	Push-in fitting	For connecting compressed air tubing with standard O.D.
3	SCA	Flow control valve	For speed regulation
4	FCZ	Dust Cover	Protects the cylinder (piston rod, seal and bearings) against a wide range of media and thus prevents premature wear
5	C	Magnetic switch	Can be integrated in the cylinder profile barrel
6	CJ	Magnetic switch bracket	For the ϕ 32-63 cylinder diameter
7	CZ	Magnetic switch components	For the ϕ 80-125 cylinder diameter
8	YY	Fish eye joint	With spherical bearing
9	YF	Y joint	With male thread

-Peripherals overview

Mounting attachments and accessories			
Serial Number	Code Name	Name	Description
10	CBG	Clevis foot	For end Caps
11	I	I joint	Permits a swivelling movement of the cylinder in one plane
12	Y	Y joint	Permits a swivelling movement of the cylinder in one plane
13	FD	Floating junction	For compensating radial and angular deviations
14	FA/FB	Front / rear flange	For bearing or end cap and Cannot be used on the bearing cap in combination with the FCZ
15	TA/TB/TC	Front / Middle / rear axle pin seat	For bearing or end cap and Cannot be used on the bearing cap in combination with the FCZ
16	LB	Axial Foundation	For bearing or end caps
17	DX	Guide unit	For protecting standards-based cylinders against rotation at high torque loads
18	CB	Double-ear	For end caps
19	LN	Hook foot seat	Used in conjunction with CB
20	CA	Single Ear	For end caps
21	CAQ	Single Ear with spherical bearing	For end caps
22	LNQ	Hook foot with bearing	With spherical bearings

Accessories

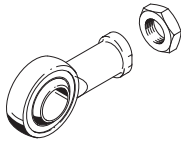
·Piston rod attachments

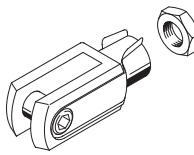
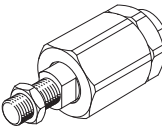
Name	For size Ø	Type	Name	For size Ø	Type
Fish eye joint YY			I joint		
	32	YY-M10x1.25		32	I-M10x1.25
	40	YY-M12x1.25		40	I-M12x1.25
	50, 63	YY-M16x1.5		50, 63	I-M16x1.5
	80, 100	YY-M20x1.5		80, 100	I-M20x1.5
	125	YY-M27x2		125	I-M27x2
	160,200	YY-M36x2		160,200	I-M36x2
	250	YY-M42x2		250	I-M42x2
320	YY-M48x2	320	I-M48x2		
Y joint			Floating junction FD		
	32	Y-M10x1.25		32	FD-M10x1.25
	40	Y-M12x1.25		40	FD-M12x1.25
	50, 63	Y-M16x1.5		50, 63	FD-M16x1.5
	80, 100	Y-M20x1.5		80, 100	FD-M20x1.5
	125	Y-M27x2		125	FD-M27x2
	160,200	Y-M36x2		160,200	FD-M36x2
	250	Y-M42x2		250	FD-M42x2
320	Y-M48x2	320	FD-M48x2		

-Accessories

· C Magnetic switch

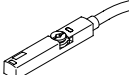
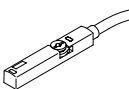
Magnetic switch-reed type is used for T-groove (with Bracket)						
	Type of mounting	Switching output	Connection	Cable length [m]	Type	For size φ
Normal open						
	Insertable in the slot from above, flush with the cylinder profile.	PNP	Magneto-resistive, 3-wire	1.3	CDX-50P-1.3	32~63
		NPN	Magneto-resistive, 3-wire	1.3	CDX-50N-1.3	
		R	Tongue spring type, 2-wire	1.3	CDX-50R-1.3	
	Insertable in the slot from above, flush with the cylinder profile.	R	Tongue spring type, 2-wire	2.5	CDX-50R-2.5	80-320
		PNP	magneto-resistive, 3-wire	1.3	CDX-21P-1.3	
		NPN	magneto-resistive, 3-wire	1.3	CDX-21N-1.3	
		R	Tongue spring type, 2-wire	1.3	CDX-21R-1.3	
				2.5	CDX-21R-2.5	

Chinese +86 400 101 8889	Germany +49 (30) 72088-0
American +01 630 995 3674	Japan +81 03 6809 1696



© Without the authorization of Hengli Pneumatic Company, any part of this brochure shall not be reproduced, edited, copied or disseminated electronically in any way. As the product is in constant development and innovation, the information in this brochure is not specific to the special conditions or applicability of a specific industry, and Hengli Pneumatic is not responsible for any incomplete or inaccurate description as generated thereby.